

# RMS-7913192A - RADIUSCX CLUTCH (DDS)

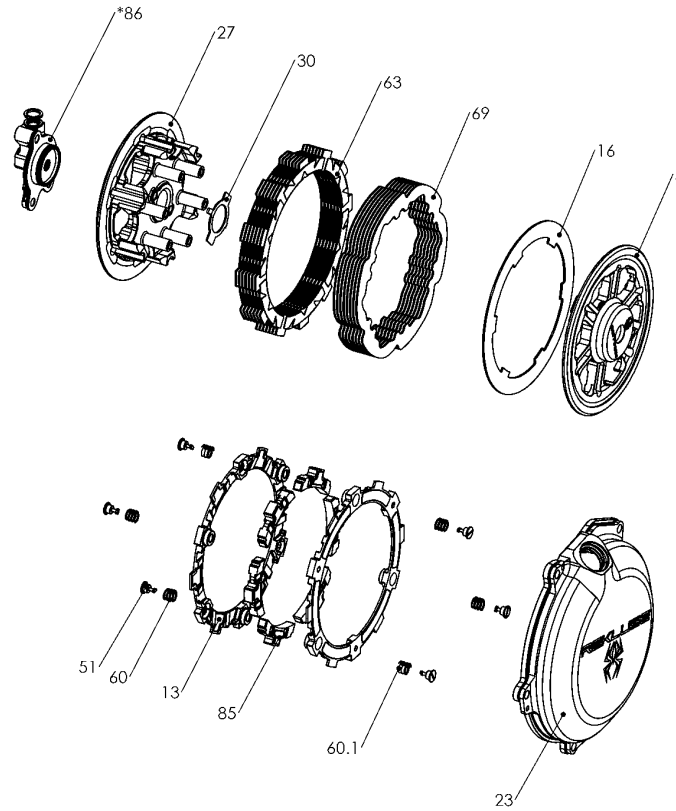

*\*SLAVE CYLINDER ASSEMBLY FICHE CAN BE VIEWED SEPARATELY.  
REBUILD KIT ALSO AVAILABLE SEPERATELY FROM REKLUSE.*

Item	Part Number	Item Description	Qty
5	113-069A	PRESSURE PLATE - Core Auto - KTM 250/350 DS	1
13	140-215C	EXP 3.0 BASE - KT350	2
16	143-010	EXP LINING PLATE - KTM	1
23	169-993A	CLUTCH COVER - KTM 250/350	1
27	178-069A	CENTER CLUTCH - CORE - KTM 250/350 DS	1
30	183-002	HARDWARE - Core Center Clutch Tab Lock Washer 27mm	1
Not Shown	411-154A	FASTENER - M5 x 20 Button-Head T-25 Torx Screw 10.9	6
Not Shown	411-906	HARDWARE - T-25 Torx Bit	1
51	415-000	FASTENER - Quarter Turn Pin	6
Not Shown	415-000	FASTENER - Quarter Turn Pin	2
Not Shown	419-120	HARDWARE - 1 Orange Free Play Gain Rubber Band	1
60	442-001	EXP ADJUSTMENT SPRING EXP - Silver	6
60.1	442-002	EXP ADJUSTMENT SPRING EXP - Red	6
60.2	442-007A	EXP ADJUSTMENT SPRING EXP - 2LB (Steel)	3
63	460-710A	DRIVE PLATE - 0.040 TEC 2 - KT 6-pin	8

# RMS-7913192A - RADIUSCX CLUTCH (DDS)

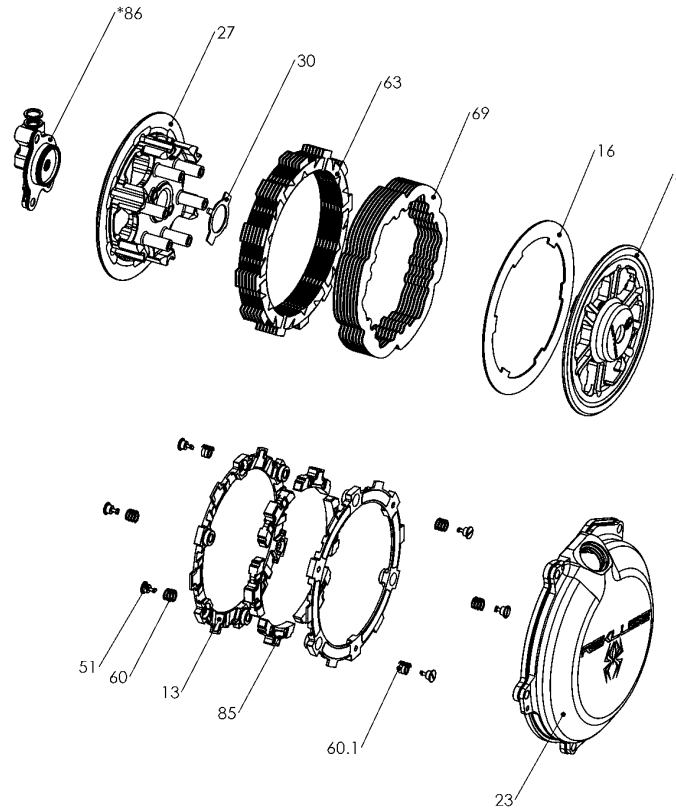

*\*SLAVE CYLINDER ASSEMBLY FICHE CAN BE VIEWED SEPARATELY.  
REBUILD KIT ALSO AVAILABLE SEPERATELY FROM REKLUSE.*

Item	Part Number	Item Description	Qty
69	469-336A	FRICITION DISK - KT350 TORQ-DRIVE - 2-Segment Pads	7
85	741-015B	EXP 3.0 WEDGE ASSEMBLY - KT350 - Heavy	6
86	742-028D	ADJUSTABLE SLAVE CYLINDER ASSEMBLY - Housing-122, Pist	1
28.1	180-107	SLAVE CYLINDER ADJUSTER - Screw, M6x7mm	1
28.3	180-122B	SLAVE CYLINDER HOUSING - KT350 Adjustable Slave Cylinde	1
28.2	180-218A	SLAVE CYLINDER PISTON - DIV 1.5	1
50	414-238	HARDWARE - 2 x 8mm Crush Washers	2
53	418-804	HARDWARE - 021 EPDM X Ring Black	1
53.1	418-907	HARDWARE - 011 EPDM O-ring	2
53.2	418-915A	HARDWARE - BUNA O-ring, size 30mmID x 1.5mmW, Black	1
53.3	418-917A	HARDWARE - 1.5x24mm Viton O-ring, 75Dur	1
Not Show	419-104	HARDWARE - 15 in L X 1/4OD. X .17ID. Clear Vinyl Tube	1
55	420-303A	GASKET - Slave Cylinder - Brembo - fits 180-122	1
56	431-304	BALL BEARING - 1/4in Chrome Steel Ball	1