

CORE EXP CLUTCH 3.0 - Yamaha YZ250F (14)

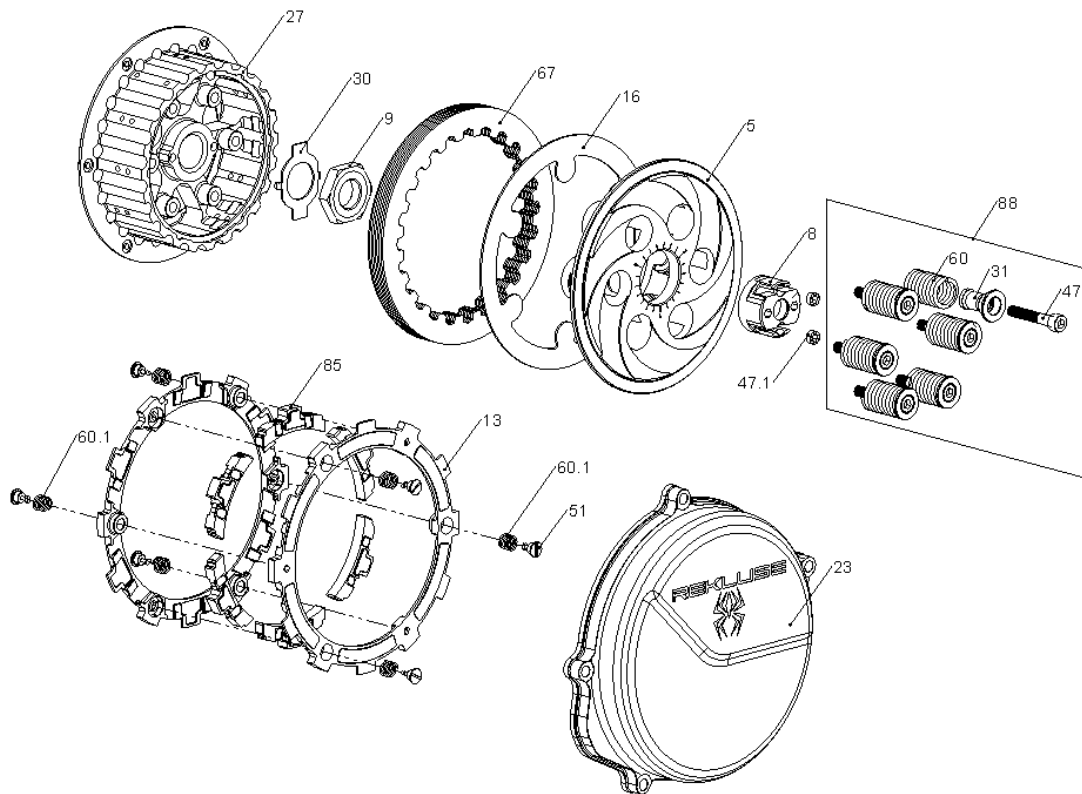

Item	Part Number	Item Description	Qty	Assembled as EXP Friction Disk
Document	191-7706A	Rekluse Core EXP Installation Guide - Cable Bikes	1	<input type="checkbox"/>
Document	192-290	CUSTOMER DOCUMENT - Safety Warnings	1	<input type="checkbox"/>
Document	193-707A	EXP/Core EXP - Troubleshooting Guide	1	<input type="checkbox"/>
Not Shown	415-000	FASTENER - Quarter Turn Pin	2	<input type="checkbox"/>
Not Shown	419-121	HARDWARE - 0.5 Black Free Play Gain Rubber Band	1	<input type="checkbox"/>
Not Shown	442-001	EXP ADJUSTMENT SPRING EXP - Light (Silver)	3	<input type="checkbox"/>
Not Shown	442-003	EXP ADJUSTMENT SPRING EXP - Heavy (Blue)	3	<input type="checkbox"/>
5	113-014A	PRESSURE PLATE - Core EXP 3.0 - 250 Class	1	<input type="checkbox"/>
8	116-771C	PRESSURE PLATE ADJUSTER - CORE EXP - Y250	1	<input type="checkbox"/>
9	117-004	CENTER CLUTCH NUT - K250/Y250	1	<input type="checkbox"/>
13	140-213A	EXP 3.0 BASE - H250	2	<input checked="" type="checkbox"/>
16	143-018A	Lining Plate 250 Class EXP 3.0	1	<input type="checkbox"/>
23	169-978B	CLUTCH COVER - Y250 (14+)	1	<input type="checkbox"/>
27	178-010C	CENTER CLUTCH - CORE EXP/CORE MANUAL - Y250	1	<input type="checkbox"/>
30	183-001A	HARDWARE - Core 450 Center Clutch Tab Lock Washer	1	<input type="checkbox"/>

47.1	411-136B	HARDWARE - Pipe Plug: 1/16 27 NPTF, 0.15 long, 4010 Annealed, face knurl	2	<input type="checkbox"/>
51	415-000	FASTENER - Quarter Turn Pin	6	<input checked="" type="checkbox"/>
60.1	442-002	EXP ADJUSTMENT SPRING EXP - Medium (Red)	6	<input checked="" type="checkbox"/>
67	465-480B	DRIVE PLATE - 0.048 Core H250 Precision	8	<input type="checkbox"/>
85	741-014A	EXP 3.0 WEDGE ASSEMBLY - H250 - Medium	6	<input checked="" type="checkbox"/>
88	744-040	CORE CLUTCH SPRING KIT - 250 - Heavy (Gold)	1	<input type="checkbox"/>
31	184-101B	HARDWARE - EXP Screw Sleeve	5	
47	411-140	FASTENER - M6-1 x 35mm Thermal Black Socket Cap Screw	5	
60	442-104	PRESSURE PLATE SPRING - 250 Class Bikes Heavy Gold	5	