



REKLUSE MOTOR SPORTS

The Rekluse Core EXP Kit with Adjustable Slave Cylinder

INSTALLATION & USER'S GUIDE

Doc ID: 191-7705A

Doc Rev: 121013

OVERVIEW

- This kit replaces the OEM core clutch components including the center clutch hub and pressure plate with high-quality billet components designed for optimal operation specific to your bike.
- Most of the OEM friction disks will be reused, but all OEM steel drive plates will be replaced with Rekluse drive plates.

©2014 Rekluse Motor Sports
Rekluse Motor Sports, Inc.
12000 W Franklin Rd
Boise, Idaho 83709
208-426-0659
support@rekluse.com

INSIDE THIS DOCUMENT

- INSTALLATION
- SETTING THE INSTALLED GAP
- CHECKING FREE PLAY GAIN
- BREAK-IN
- MAINTENANCE
- EXP TUNING OPTIONS & ENGAGEMENT SETTINGS
- SLAVE CYLINDER APPENDIX (only some models)
- TROUBLESHOOTING GUIDE

INSTALLATION TIPS



- Watch the “CORE EXP Auto-Clutch Installation Video” by following this QR code or visiting rekluse.com/videos.
- Read this entire document before performing any steps, so you will know what to expect.
- Be sure to use proper eye protection.
- Laying the bike on its left side makes clutch work easier and eliminates the need to drain the oil.
- An air or electric impact wrench works well to remove the center clutch nut, or you can place the bike in top gear and hold the rear brake while loosening the center clutch nut with a socket.
- Channel-lock pliers work best to bend the tabs of the washer up over the center clutch nut.
- Use clean, quality JASO MA certified transmission oil for best performance.
- Bikes with taller gearing or modified engines with increased horsepower may require heavier wedges and/or stiffer pressure plate springs which can be purchased separately from Rekluse.

TOOLS NEEDED

- 8mm socket
- 27mm socket (most models)
- 8mm & 12mm end wrenches
- 4mm & 5mm Allen keys
- Torque wrench (in-lb & ft-lb, or N-m)
- Channel-lock pliers
- Hydraulic clutch fluid

INCLUDED PARTS

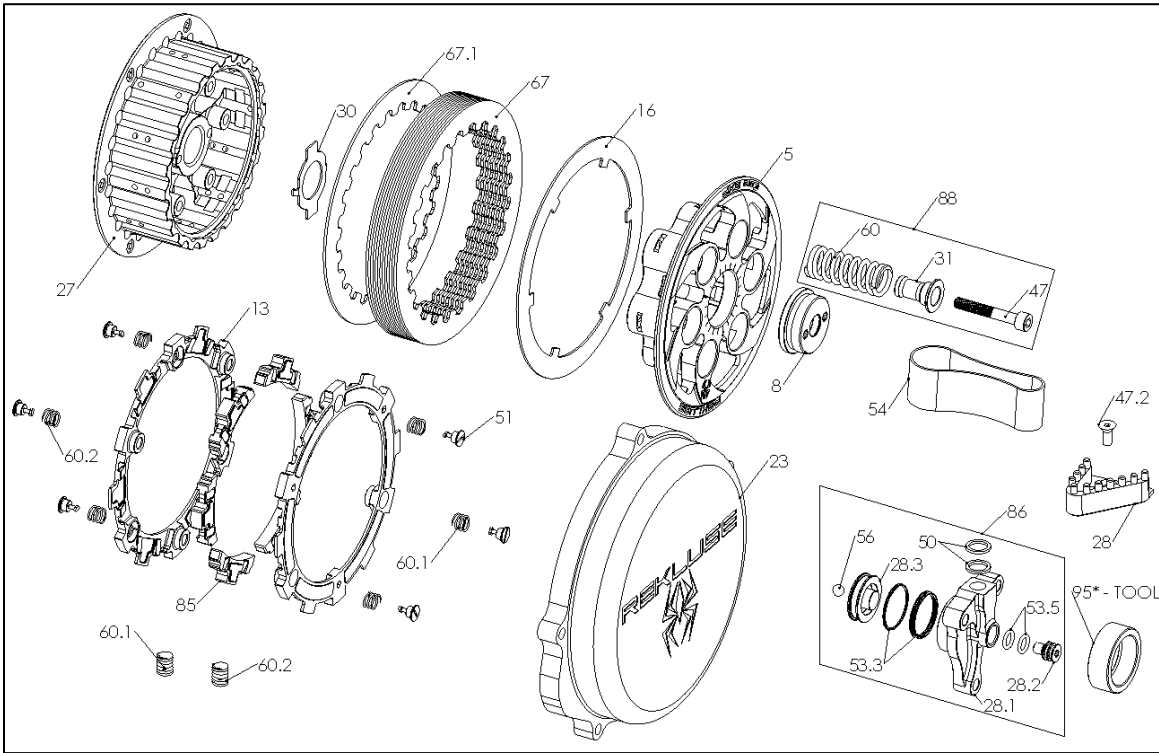

Item	Item Type	Qty
5	Pressure Plate	1
8	Pressure Plate Plug	1
13	EXP Base *	2
16	Steel Lining Plate	1
23	Clutch Cover	1
27	Center Clutch Hub	1
28	Brake Tip (<i>only some KTM & Husaberg models – see “Clutch Cover” section</i>)	1
30	Lock-Tab Washer	1
31	Screw Sleeve ^^	5/6
47	Fastener – M6 Screw (requires 5mm Allen tool) ^^	5/6
47.1	Pipe Plug	2
51	Fastener - 1/4-Turn Pin *	6
54	Free Play Gain Rubber Band	1
60	Pressure Plate Spring ^^	5/6
60.X	EXP Adjustment Spring * (extra included, see last page for tuning options)	6
67	Steel Drive Plate ++	6-9
67.1	Steel Drive Plate – Thin (.040” [1.0mm]) ++	0/1
85	Wedge Assembly *	6
86	Adjustable Slave Cylinder Assembly (bleed syringe included)	1
87	Throwout Assembly (<i>only certain models</i>)	1
88	Core Clutch Spring Kit Assembly	1

* Denotes parts assembled as a component of the EXP disk assembly

++ Depends on model – see “Hub & Clutch Pack Installation” section

^^5 for 250F class bikes, 6 for 450F class bikes including 250 2-strokes

Visit rekluse.com/support for a full parts fiche illustration and part numbers.

PREP & DISASSEMBLY

1. Lay the bike on its left side. Catch any fuel that might drain in a suitable container. Remove the clutch cover.



2. Remove the OEM clutch parts named in the following diagram. Leave the basket installed.

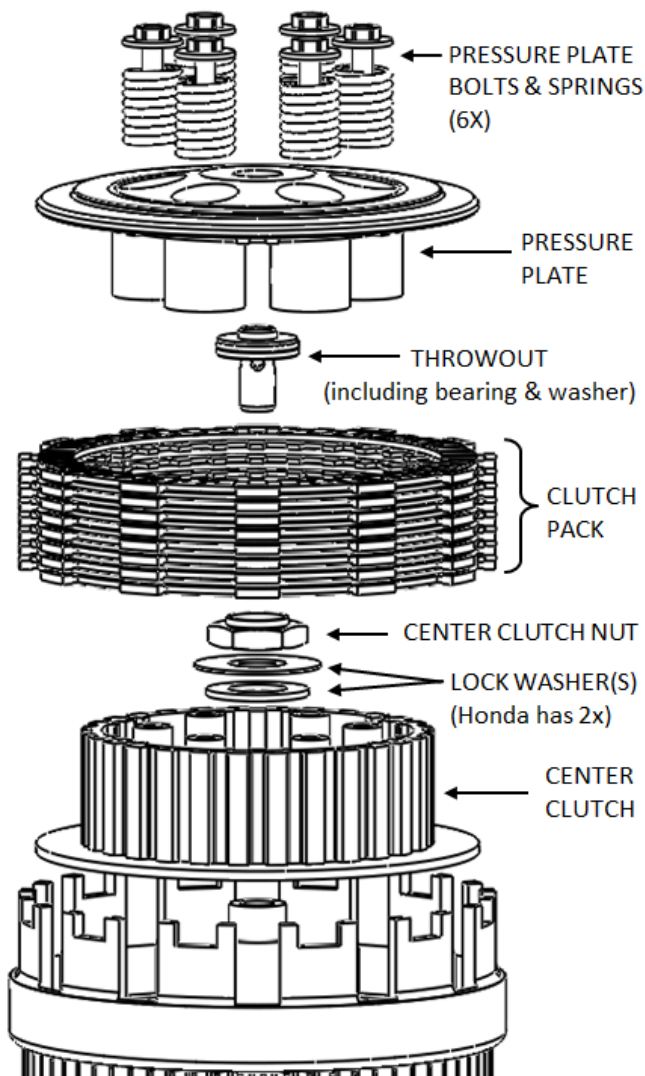

3. Separate the OEM clutch pack.

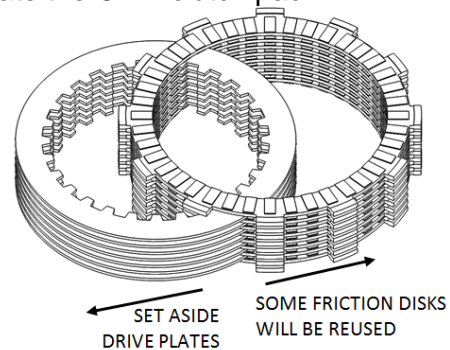

Inspect the friction disks for signs of heat or wear. Replace if they are burnt or worn. For most models, new friction disks can be purchased from Rekluse.

4. Inspect the basket for cushion slop or notching. If notched or worn, it is recommended to install a Rekluse Billet Clutch Basket (available for most models).

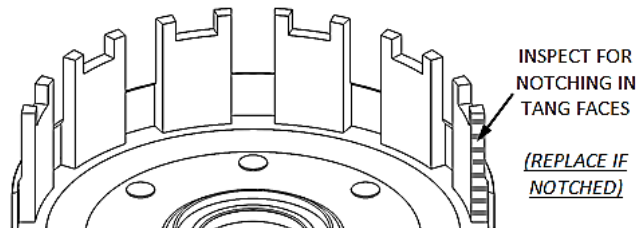

5. Soak the EXP disk in engine oil for 5 min.

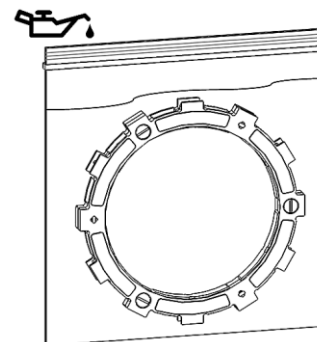

HUB & CLUTCH PACK INSTALLATION

6. Install the new center clutch hub on top of the OEM thrust washer.

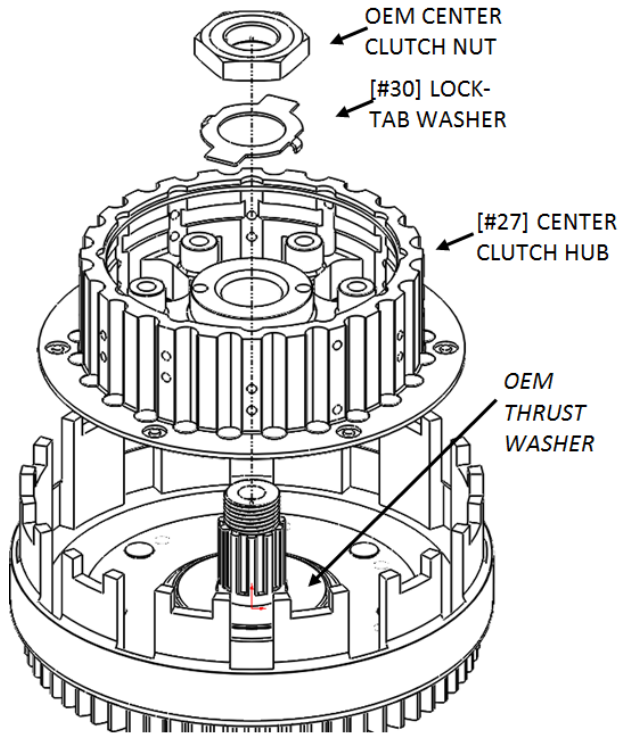

NOTE: If the OEM thrust washer is not in place, it is probably stuck to the backside of your OEM center clutch hub.

7. Torque the nut to 50 ft-lb (70 N-m), then bend both tabs up. **DO NOT OVER TORQUE**, or the clutch will drag and damage may occur.

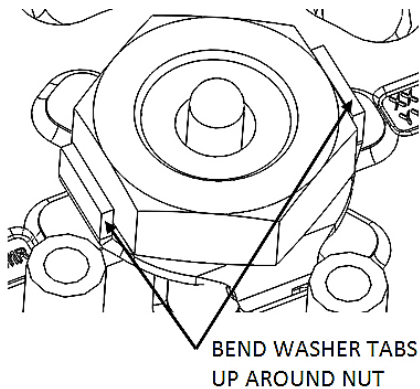

8. Install the new clutch pack.

NOTE: Some OEM Baskets have “half-slots” at the top of the basket tangs. Rekluse products require that **all friction disks, including EXP disk, are seated into the MAIN (deeper) basket slots.**

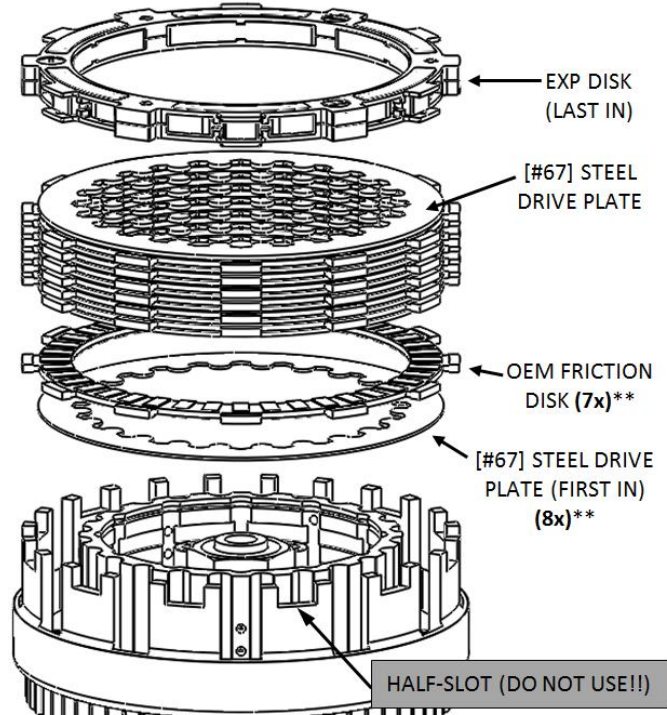

** 450+ CC 4-STROKES & 250+ CC 2-STROKES ONLY:
USE THE .040" (1mm) DRIVE PLATE [#67.1] ON BOTTOM

Model-Specific Clutch Pack Notes:

** **Beta (all models) &**

** **KTM 125/144/150/200cc 2-strokes**

Your clutch pack will consist of only 6x OEM friction disks and 7x Rekluse Drive Plates.

** **Sherco (all models)**

Your clutch pack will consist of 8x OEM friction disks and 9x Rekluse Drive Plates.

Any models that have an OEM clutch boss spring: Do not reinstall the clutch boss spring.

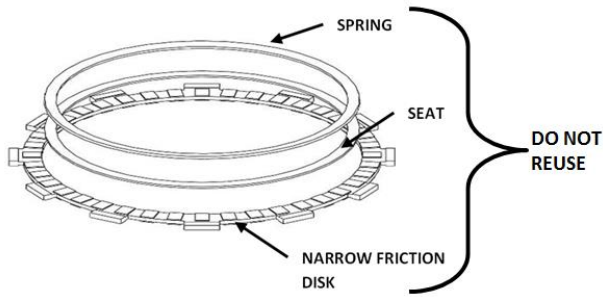

9. *Beta, Sherco, GasGas, Husqvarna, and KTM 125-200 owners, skip to the next step. All other models, reinstall the OEM throwout assembly.*

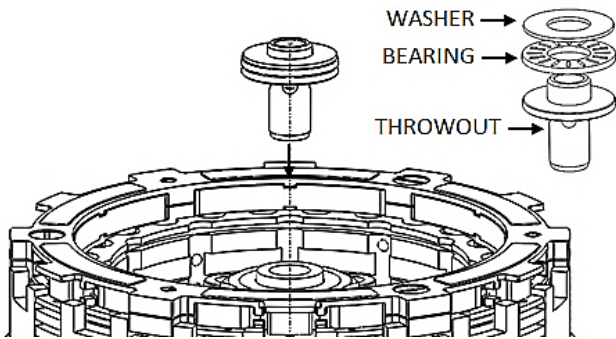

NOTE: If you are missing the top washer, it is probably stuck to the backside of your OEM pressure plate.

10. Model-Specific Throwout Assemblies:

Beta, GasGas, & Husqvarna 450/510cc only: Install the included Rekluse throw-out assembly in the order shown.

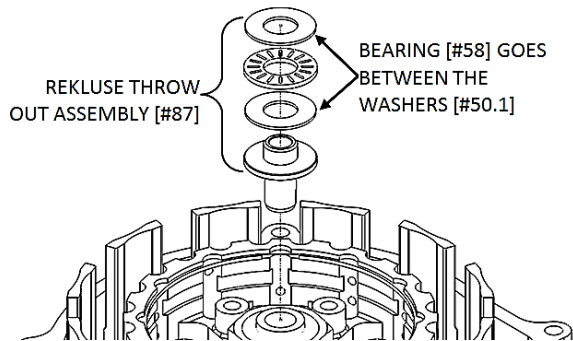

Husqvarna 125cc ('14 and newer) & KTM 125/144/150/200cc ('06 & newer): Install the included throw out spacer onto the OEM throw out.

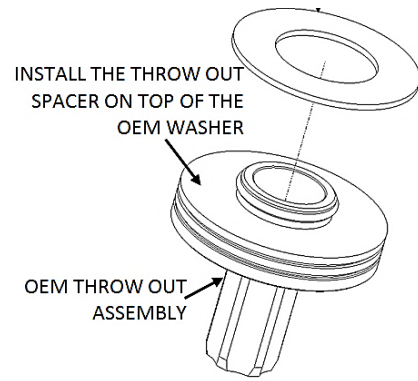

Sherco only:

Replace the OEM throwout washer with the included washer.

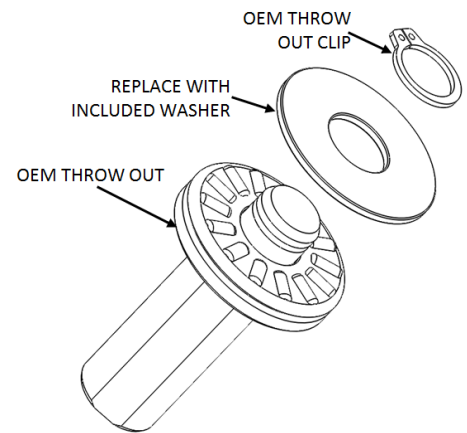

PRESSURE PLATE INSTALLATION

11. Place the Lining Plate [#16] onto the Rekluse Pressure Plate [#5]. Adding an oil film between them will help them stick together for ease of installation.

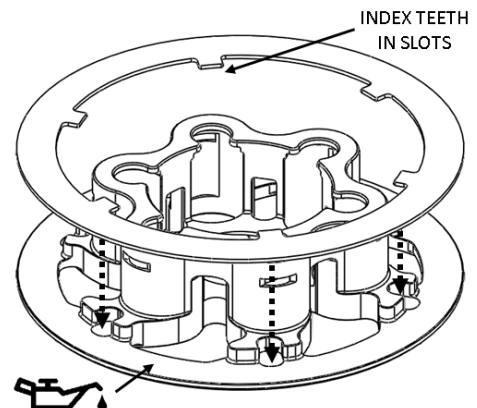

12. Install this pressure plate subassembly.

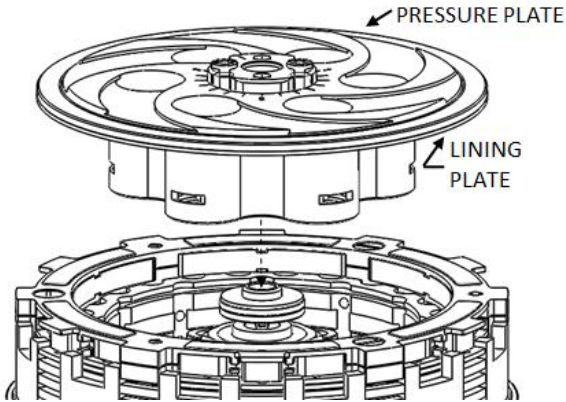

13. Install the pressure plate springs.

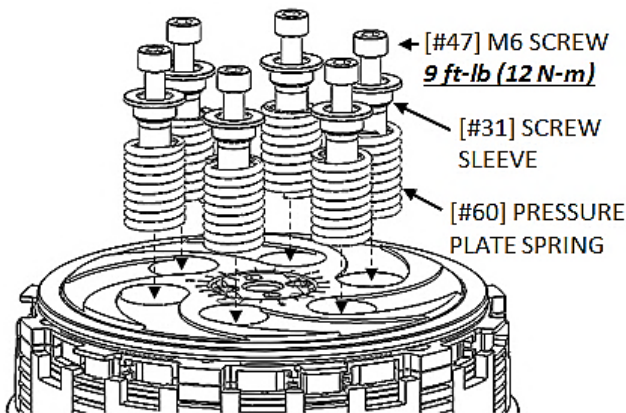

Model-Specific Spring Notes:

Husqvarna 125cc ('14 and newer) & KTM 125/144/150/200 2-stroke Owners: Your kit includes 2 types of pressure plate springs: green and red (5 of each). **KTM 200 owners use the 5 GREEN springs.** 125/144/150 owners can opt to use the lighter RED springs.

Beta 250/300 2-stroke Owners: Your product includes a 2-color spring kit, 3 of each color: Alternate spring colors clockwise when installing them to ensure even clamping force on the pressure plate.

CLUTCH COVER

14. Your new Core EXP clutch is taller than the OEM clutch, so the Rekluse Clutch Cover has been designed for clearance with all moving parts. You must use the Rekluse Clutch Cover or interference and clutch damage will occur.

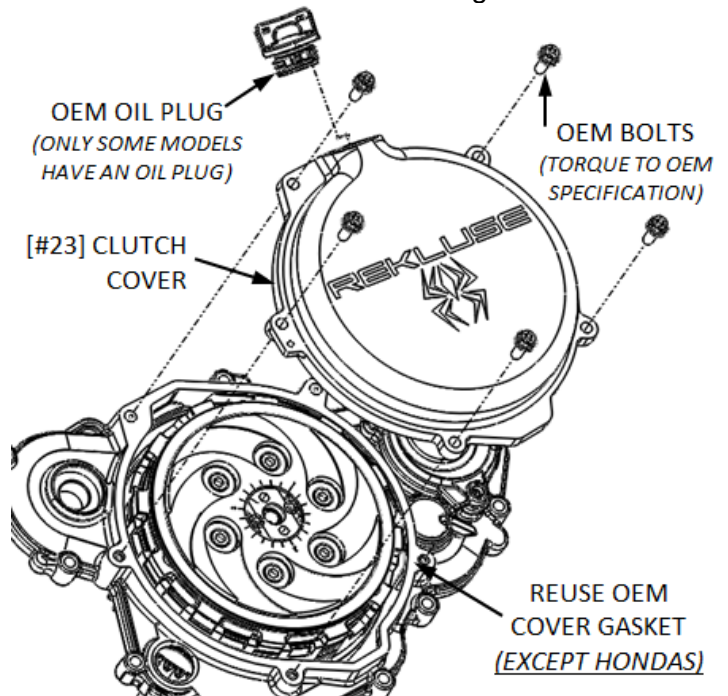

Model-Specific Clutch Cover Notes:

KTM 400/450/505/530cc ('08-'11) & Husaberg 390/450/570cc FE/FX ('09-'12)

To provide clearance between the cover and brake pedal tip, remove the OEM tip and replace it with the included Rekluse tip using the provided hardware and Loctite. Your pedal

position will need to be lowered about ¼-inch (6-mm), so the Rekluse tip is taller to compensate. Refer to your owner's manual for instructions about properly adjusting brake pedal height.

SLAVE CYLINDER INSTALLATION

Handle with care! During assembly there is a small ball bearing [#56] installed in the slave piston [#28.3] with a small amount of grease. When installing the Rekluse slave cylinder, make sure the ball does not come loose.

15. Stand the bike up and lean it on its kickstand or place it on a suitable bike stand.

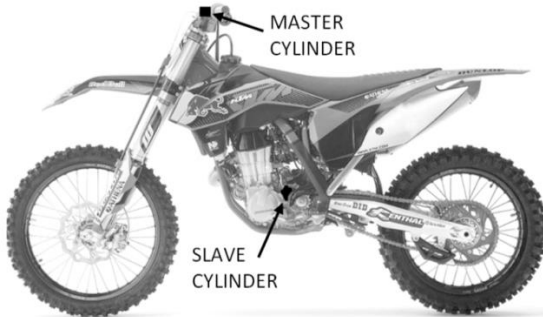

16. Starting at the slave cylinder, remove the OEM parts named in the following diagram beginning with the banjo bolt.

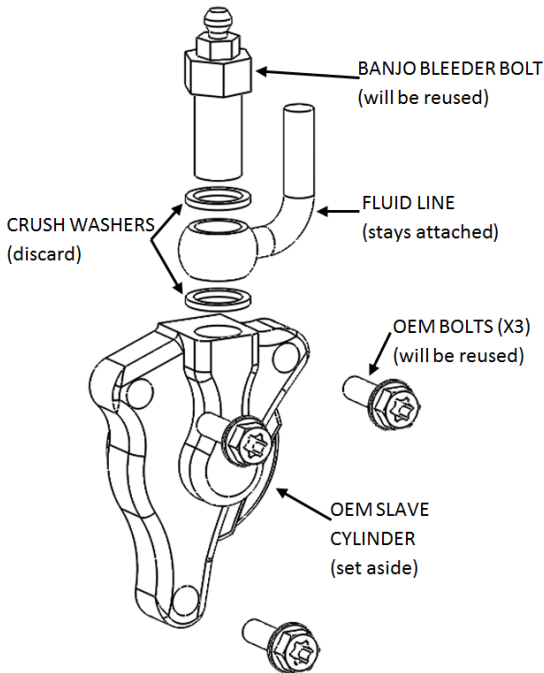

17. On a workbench (still away from the engine), bleed the Rekluse slave cylinder by this procedure:

a. Use a 4mm Allen key to make the top O-Ring [#53.1] visible on the adjuster screw [#28.2].

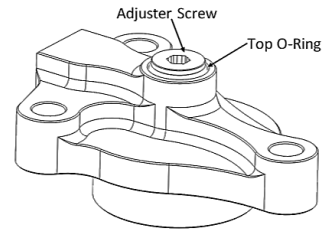

b. Compress the piston [#28.3] until it bottoms.

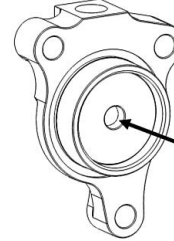

c. Pour clutch fluid into the slave cylinder port.

WARNING
Be sure to use the correct clutch fluid! Check the cap of the clutch master cylinder to determine which clutch fluid to use. Failure to use the correct fluid will result in seal damage and/or failure.

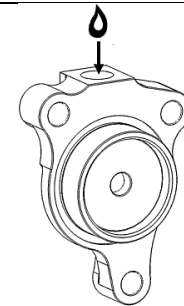

d. Turn the adjuster screw clockwise until it bottoms, keeping the fluid topped off.

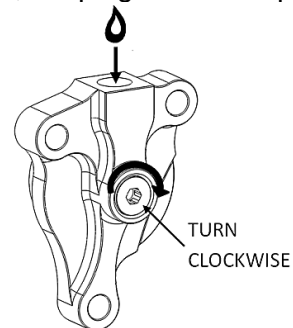

e. Turn the adjuster screw back to the initial position with the top O-ring visible.

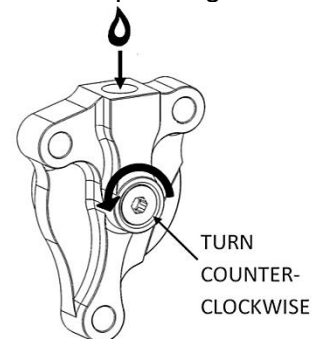

- f. Compress the piston until it bottoms out. Repeat the process until there is no longer air escaping from the top port when the piston is compressed.

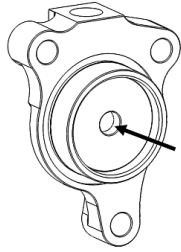

NOTE: When compressing the piston, fluid can shoot out from the slave cylinder port. Be sure to wear eye protection.

18. Check that the ball bearing [#56] is still in place.

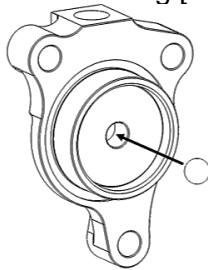

19. Install the Rekluse slave cylinder on the bike using these parts, ending with the banjo bolt.

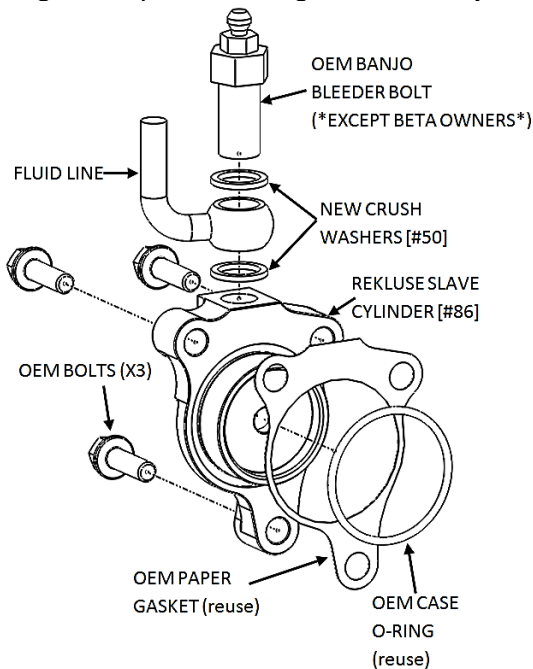

NOTE: Some models have a paper gasket and/or O-ring seal. Reuse them if OEM equipped. ***BETA OWNERS:** Use the supplied banjo bleeder bolt in place of the OEM banjo bolt.

If you are installing one of the following products, see the Slave Cylinder Appendix sheet for chain guard fitment instructions:

- **RMS-7700 GasGas**
- **RMS-7724 Sherco**
- **RMS-7727 Husaberg**
- **RMS-7755 Husqvarna**

20. Optional: If you purchased the Rekluse Slave Guard accessory (available for most models), install it now using the instructions in the kit.

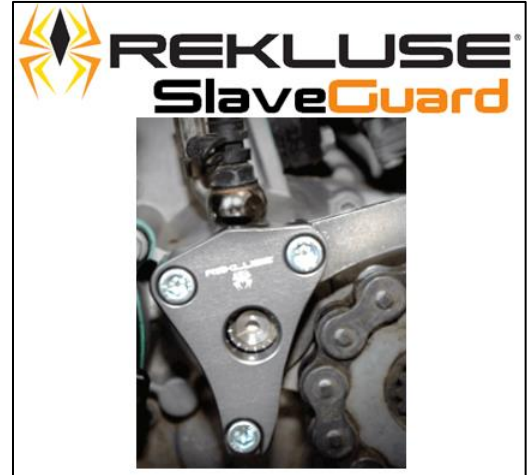

21. Remove the cap and bladder from the clutch master cylinder and top off the clutch fluid.

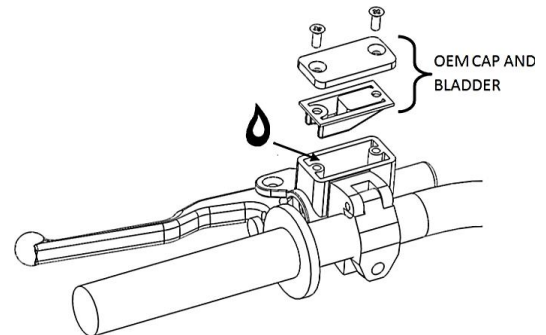

22. Attach the supplied bleed tube to the banjo bolt port and loop it into a suitable catch bottle.

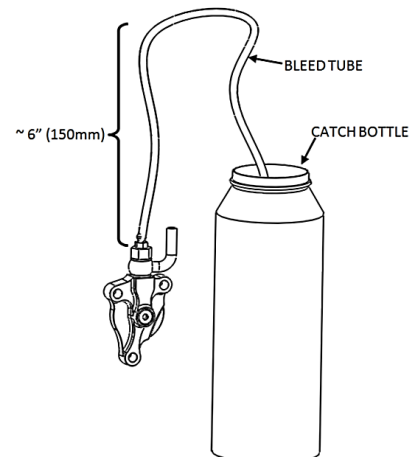

23. Pump the clutch lever 3-5 times then hold it against the bar/grip.

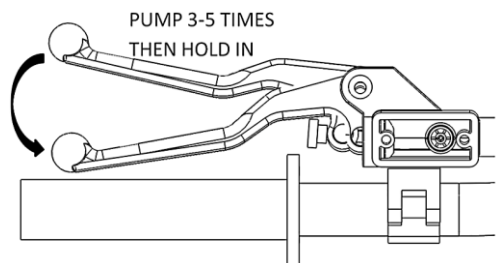

24. Using an 8mm wrench, open the bleed port. Air and fluid should come out of the bleed tube. Tighten the bleed port.

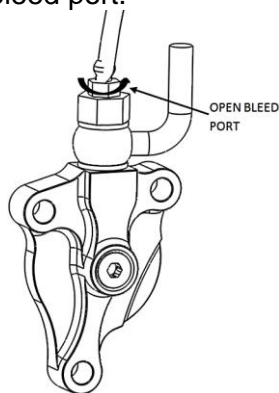

25. Slowly release the clutch lever and check the fluid level in the clutch master cylinder.

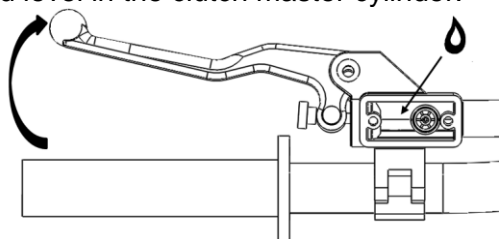

26. Repeat the previous 3 bleeding steps until air no longer comes out of the bleed port. Then, check that the clutch lever functions properly. Repeat the bleeding procedure if necessary.

27. Finally, remove the bleed tube.

INSTALLED GAP SETTING

DEFINITION: “Installed Gap” is the separation in the clutch pack created by the adjustment of the Adjuster Screw in the Slave Cylinder. This gap is what allows the clutch to spin freely until the desired RPM is reached for engagement; it must be set correctly for optimal performance.

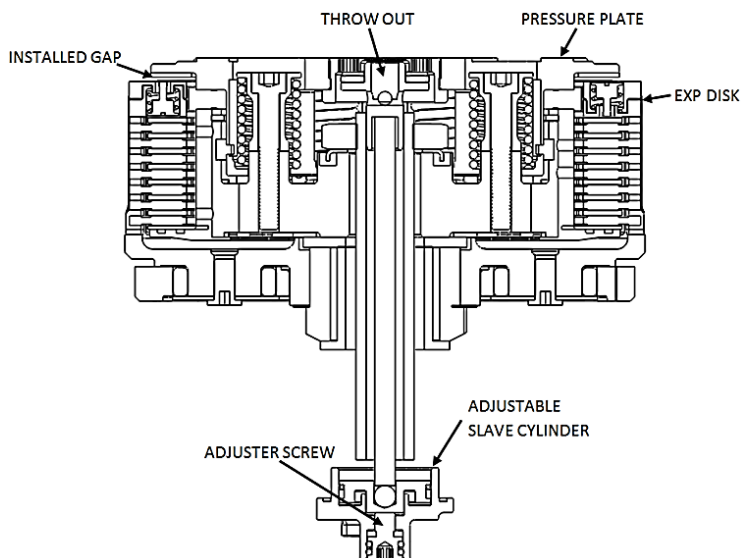

28. Using the long end of a 4mm Allen key, turn the adjuster screw clockwise until it stops under moderate pressure. You are trying to feel for the point at which the throwout will start to lift the pressure plate. This is the “starting point”.

NOTE: It may take a few tries to find the point at which the system is bottomed out. You should feel a distinguishable change in turning effort at this point.

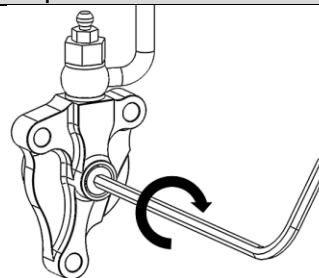

29. Once you have found the starting point, turn the adjuster clockwise 1 full turn plus 5 marks (or “1+5”). **This is NOT your final setting**, but it is a good reference point for using free play gain to find the correct setting.

30. Top off the master cylinder with clutch fluid and reinstall the OEM cap and bladder.

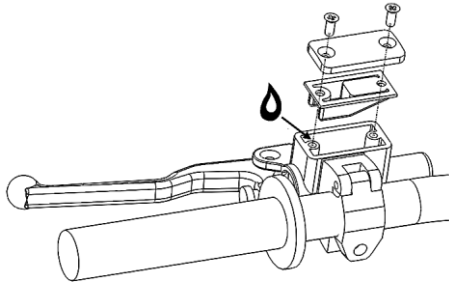

CHECKING LEVER FREE PLAY GAIN

WARNING

Always make sure that the bike is in NEUTRAL before checking Free Play Gain. Failure to do so may result in the bike lurching forward, and loss of control and/or injury may result.

NOTE: Before performing this step, please visit our website at rekluse.com/support to view the TECH VIDEO entitled “How to Check Free Play Gain”.



“Lever Free Play” is essentially the “slack” in the clutch lever before it starts actuating the clutch. Applying a light finger pressure will take up this slack.

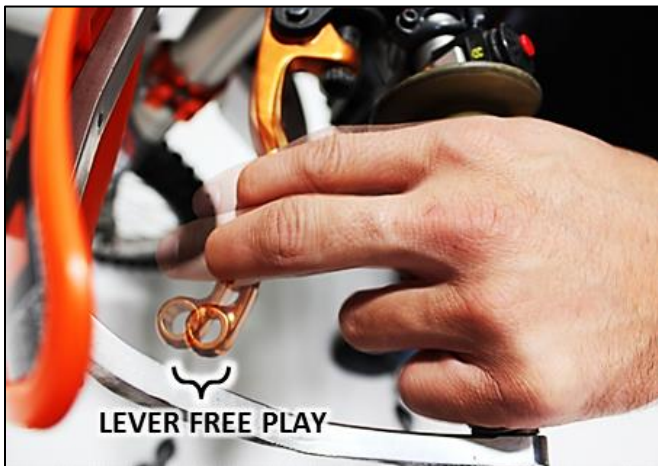

“Free Play Gain” is the increase of lever free play as the auto-clutch engages. This happens when the RPM increase from idle through around 5,000 RPM. Free Play Gain is caused by the expansion of

the EXP disk which lifts the pressure plate away from the throwout assembly.

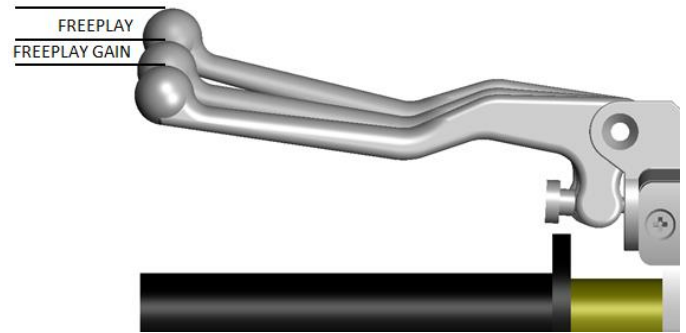

Optimal Free Play Gain yields **1/8” (3mm)** of clutch lever movement, measured at the end of the lever. This measurement at the lever correlates to achieving the ideal installed gap.

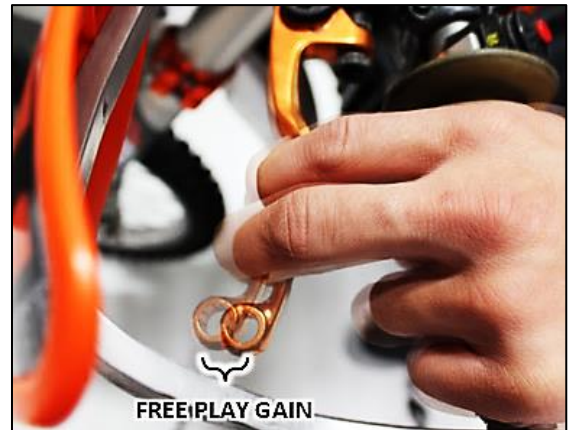

The following steps explain two ways to check Free Play Gain. One will use the rubber band that has been included in the clutch kit and one explains using your hand, which you will perform before every ride.

Place the bike in neutral, start the engine and let it warm up for 2-3 minutes.

Rubber Band Method:

It is recommended that you use this method first to find your Free Play Gain so you can see what it is. Then, check it by hand as well so that you can effectively and comfortably check free play gain every time you ride.

Wrap the included rubber band around the outer end of the handlebar grip and attach it to the ball end of the clutch lever.



With the bike at idle in neutral, quickly blip (rev) the engine to at least 5,000 RPM and let it return to idle. **The clutch lever should move in about 1/8" (3mm) toward the handlebar as you rev the engine.**

Note: If you are not getting the correct lever movement, see the "Free Play Gain Troubleshooting Guide" on the next page.

Hand Method:

Free play gain should also be checked using your hand, as you will check it by hand before every ride. With the bike at idle, apply enough pressure to the lever to take up the initial freeplay (slack) shown in the photos on the previous page. While continuing to apply light pressure, rev the engine to at least 5,000 RPM. **The clutch lever should move in 1/8" (3mm) under your finger pressure as you rev the engine and the auto-clutch engages.**

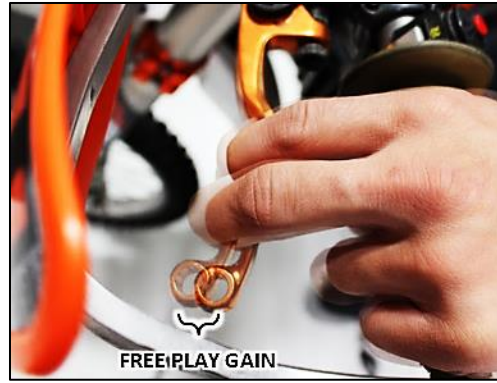

BREAK - IN

Follow these procedures for a new installation and any time new friction disks or EXP bases or wedges are installed.

1. Rev cycles: Warm up the bike for 2-3 minutes. With the bike in neutral and your hand **off** of the clutch lever, rev the engine 10 times, being sure to let it **return to idle** between each rev cycle.
2. With the engine running, pull in the clutch lever and click the bike into gear. Slowly release the clutch lever. The bike should stay in place, perhaps with a slight amount of forward creep.
3. Now that the bike is idling in first gear, slowly apply throttle to begin moving. To break in the clutch components, perform the following roll-on starts in 1st and 2nd gear without using the clutch lever: In 1st gear, accelerate moderately to approximately 5,000 RPMs and come to a stop—repeat this 5 times. Next, starting in 2nd gear, accelerate moderately to approximately 5,000 RPMs then come to a stop—repeat this 5 times.
4. Now that the EXP is broken-in and the clutch is warm, re-check free play gain at your clutch lever and adjust if necessary. Your clutch pack will expand with heat, so final adjustments should be made when the bike is warm. Now you are ready to ride!

WARNING: DO NOT RIDE WITHOUT SUFFICIENT FREE PLAY GAIN!

Checking free play gain is easy and takes less than a minute to perform. For optimum performance and longevity, check free play gain when the bike is warm at the start of every ride.

FREE PLAY GAIN

TROUBLESHOOTING

Each adjustment should be done in small increments - one tick mark at a time. After each adjustment, repeat the rev-cycle until optimal free play gain is achieved.

Symptom:

- Clutch lever moves in too far (too much free play gain)
- Clutch has excessive drag
- It is difficult to fully override the clutch with the lever

Answer: Installed Gap is too small

Solution: Turn the Adjuster Screw inwardly (clockwise) to increase the Installed Gap.

Symptom:

- Clutch lever does not move enough or does not move at all (too little free play gain)
- Clutch is slipping

Answer: Installed Gap is too large

Solution: Turn the Adjuster Screw outwardly (counter-clockwise) to reduce the Installed Gap. It may be helpful to re-find the starting point.

CLUTCH NOISE

Although it is harmless, some bike models may have “squeal” or “chatter” coming from the clutch at low RPM as it engages. Clutch squeal is caused by the clutch components vibrating as the clutch engages and can become more audible as the clutch gets hot. For bike models that tend to have clutch squeal or chatter here are some recommendations to reduce or eliminate it:

- **Oil:** Rekluse recommends that you have fresh, clean JASO-MA rated oil for best clutch performance. Dirty or old oil can make the clutch more likely to squeal or chatter. Some heavy-duty oil stabilizers or other additives have been known to reduce noise and make shifting smoother. Be sure that any additives

you might use are approved for use in wet-clutch motorcycles.

- **Clutch Basket:** Available for some models, a Rekluse Clutch Basket will eliminate clutch squeal and chatter in most cases because it is precision machined from high quality material and includes long-life clutch dampers. A clutch basket that is damaged or has worn-out dampers tends to increase clutch noise.
- **Installed Gap:** Adjusting the Installed Gap will NOT affect clutch squeal or chatter

MAINTENANCE

- Maintain adequate free play gain, checking before every ride and adjusting if necessary.
- Keep up with regular oil changes as per the bike manufacturer’s recommendations. Clutch function and longevity depends on oil quality.
- Inspect all of your clutch parts **every 40 hours** for signs of wear or excessive heat, and replace components as necessary.

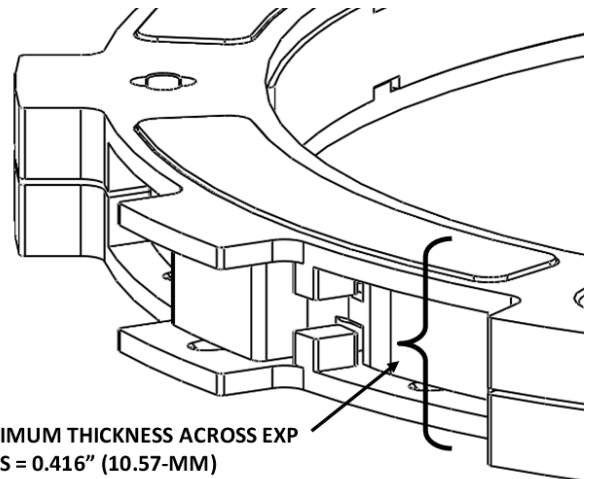

- Repeat the break-in procedure anytime the friction disks or EXP bases or wedges are replaced. Always soak friction disks or EXP bases in oil for at least 5 minutes before installing.

EXP TUNING OPTIONS

Included are spring options to tune the engagement RPM of the EXP disk. The EXP disk comes set with the recommended “**Medium**” setting from Rekluse. See chart on next page for setting options.

Adjusting the engine idle speed to match your engagement setting is important and greatly affects the overall feel of how the EXP disk engages. To prevent freewheeling and maximize engine braking, set the idle so there is a slight amount of drag while the bike is idling in gear and warmed up. The idle should not be so high as to move the bike forward in gear with the throttle closed. However, with a small opening of the throttle the bike should move forward.

It is **NOT necessary** to disassemble the EXP halves to change springs! To change springs, remove 3 of the ¼-turn pins from one side of the EXP, replace springs, and re-install ¼-turn pins. Next, flip the EXP disk over and repeat on the other side if necessary. To maintain even pressure when using two different color spring sets, install one color set of 3 on one side of the EXP and the remaining color set of 3 on the other side.

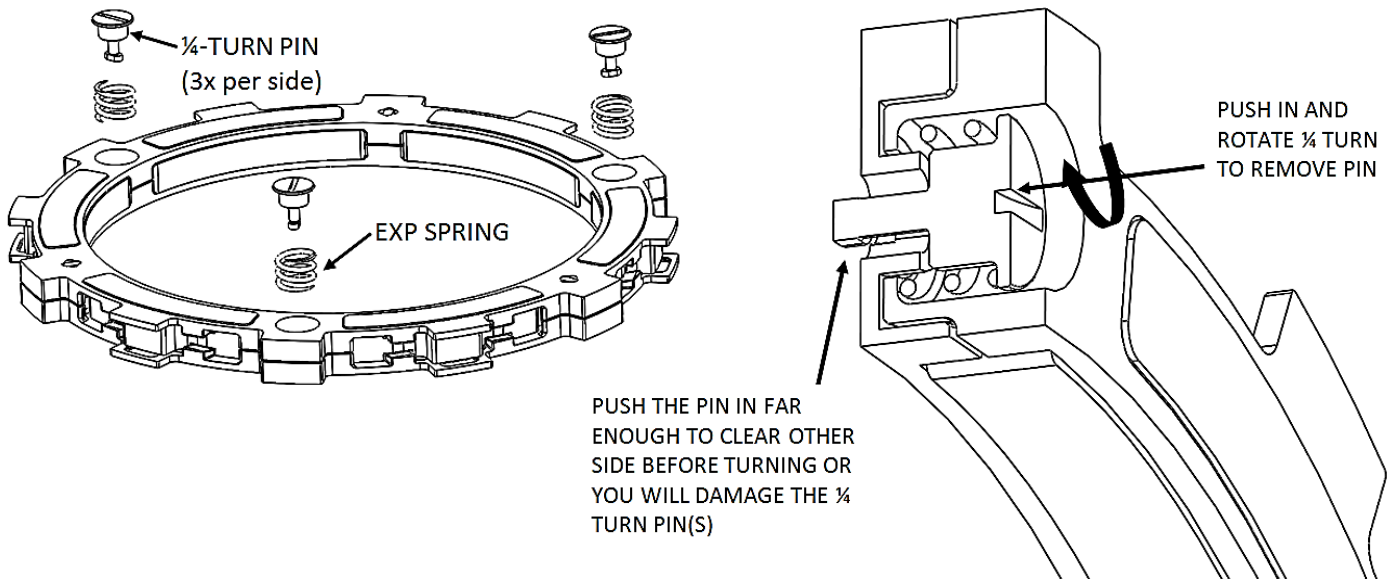

CAUTION: If you disassemble the EXP, bearing pads may fall out or be stuck to the ramp surfaces of the EXP bases. Take care to ensure all pads are correctly placed into wedge pockets using gentle pressure to avoid damage to the pad surfaces before reassembling the EXP. Properly seated pads will be secured in place once the EXP is reassembled. Operating the clutch without the pads in place will cause part damage or failure.

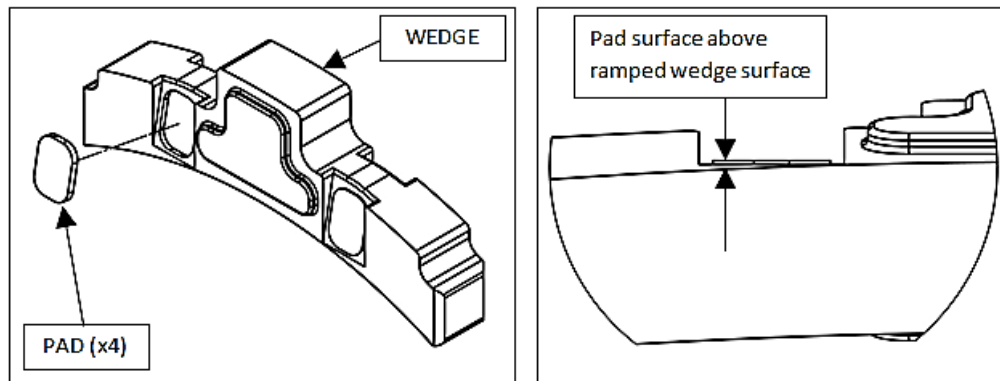

EXP ENGAGEMENT SETTINGS BY PRODUCT

Make	Bike Model	Product	Low Springs	Medium Springs	High Springs
GasGas	250/300	RMS-7700	6 Red	3 Red 3 Blue	6 Blue
Honda	CRF450R	RMS-7710	6 Red	3 Red 3 Blue	6 Blue
Honda	CR250R	RMS-7711	6 Red	3 Red 3 Blue	6 Blue
Honda	CRF250R	RMS-7712	3 Silver 3 Red	6 Red	3 Red 3 Blue
Honda	CRF250X	RMS-7712	6 Silver	3 Silver 3 Red	6 Red
Honda	CRF450R	RMS-7713	6 Red	3 Red 3 Blue	6 Blue
Honda	CRF450R	RMS-7714	6 Red	3 Red 3 Blue	6 Blue
Honda	CRF250R	RMS-7716	3 Silver 3 Red	6 Red	3 Red 3 Blue
Honda	CRF450X	RMS-7719	6 Red	3 Red 3 Blue	6 Blue
Beta	250/300	RMS-7721	6 Red	3 Red 3 Blue	6 Blue
Beta	350/400/450/498/520	RMS-7723	6 Red	3 Red 3 Blue	6 Blue
Sherco	250/300	RMS-7724	6 Silver	3 Silver 3 Red	6 Red
Husaberg	FE 390/450/570	RMS-7727	6 Red	3 Red 3 Blue	6 Blue
KTM	450/505 SXF/XCF	RMS-7730	6 Blue	3 Blue 3 Gold	6 Gold
KTM	400/450/530 EXC/XCR	RMS-7732	3 Red 3 Blue	6 Blue	3 Blue 3 Gold
KTM	250/300 SX/XC/XCW	RMS-7736	6 Red	3 Red 3 Blue	6 Blue
KTM	125/144/150/200	RMS-7737	6 Silver	3 Silver 3 Red	6 Red
KTM	250 SXF/XC-F/XCFW	RMS-7738	3 Silver 3 Red	6 Red	3 Red 3 Blue
Kawasaki	KX250F	RMS-7740	3 Silver 3 Red	6 Red	3 Red 3 Blue
Kawasaki	KX450F / KLX450F	RMS-7745	6 Red	3 Red 3 Blue	6 Blue
Husqvarna	TC/TE 310	RMS-7755	6 Silver	3 Silver 3 Red	6 Red
Husqvarna	TC/TXC/TE 250	RMS-7755	6 Silver	3 Silver 3 Red	6 Red
Husqvarna	TC/TE 450/510	RMS-7756	6 Red	3 Red 3 Blue	6 Blue
Suzuki	RMZ450	RMS-7764	3 Red 3 Blue	6 Blue	3 Blue 3 Gold
Suzuki	RMZ250	RMS-7767	6 Red	3 Red 3 Blue	6 Blue
Yamaha	YZ250	RMS-7770	6 Red	3 Red 3 Blue	6 Blue
Yamaha	YZ250F / WR250F	RMS-7771	3 Silver 3 Red	6 Red	3 Red 3 Blue
Yamaha	YZ450F / WR450F	RMS-7773	6 Blue	3 Blue 3 Gold	6 Gold
Yamaha	YZ450F	RMS-7776	6 Blue	3 Blue 3 Gold	6 Gold
Yamaha	YZ250F	RMS-7778	3 Silver 3 Red	6 Red	3 Red 3 Blue

REKLUSE®



©2014 Rekluse Motor Sports
 Rekluse Motor Sports, Inc.
 12000 W Franklin Rd
 Boise, Idaho 83709
 208-426-0659
 support@rekluse.com