



REKLUSE MOTOR SPORTS

The Rekluse EXP Kit for KTM 950, 990 LC8

INSTALLATION & USER'S GUIDE

Doc ID: 191-6331A
Doc Rev: 042417

OVERVIEW

- This kit replaces most of the OEM clutch pack with a Rekluse-designed clutch pack intended for optimal operation specific to your bike.
- Some of the OEM clutch disks will be retained with the installation of the Rekluse components. This is necessary to achieve the desired operation, performance, and spacing within the clutch.

INSIDE THIS DOCUMENT

- PREP & DISASSEMBLY
- CLUTCH INSTALLATION
- SETTING THE INSTALLED GAP & BREAK-IN
- TROUBLESHOOTING
- EXP TUNING OPTIONS & ENGAGEMENT SETTINGS
- MAINTENANCE

INSTALLATION TIPS

- Watch related installation & technical videos by following this QR code or visiting rekluse.com/videos.
- Read this entire document before performing any steps, so you will know what to expect.
- Be sure to wear proper eye protection.
- Leaning the bike allows for easy clutch access and eliminates the need to drain oil.
- Use clean, quality JASO MA certified oil for motorcycle transmissions for best performance.
- When reinstalling components, use the torque specifications found in your OEM service manual.



©2016 Rekluse Motor Sports, Inc.
12000 W Franklin Rd
Boise, Idaho 83709
208-426-0659
support@rekluse.com

TOOLS NEEDED

- Metric socket set & end-wrench set
- 4mm Allen key
- Torque wrench (in-lb & ft-lb, or N-m)
- Calipers

INCLUDED PARTS

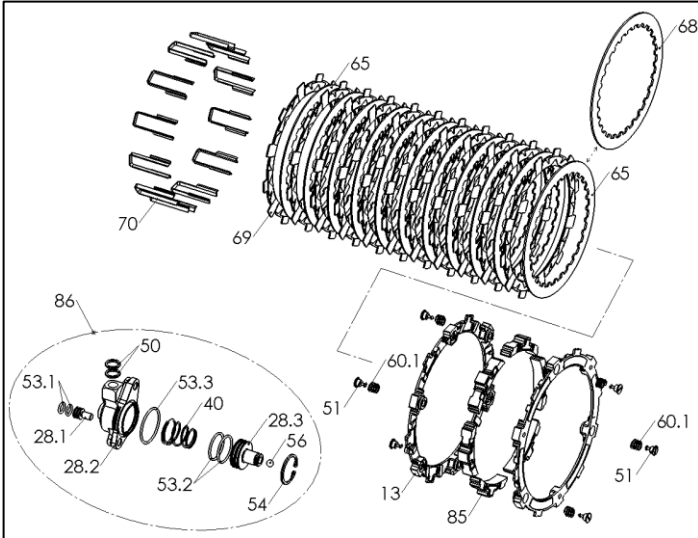

Item	Item Type	Qty
13	EXP Base *	2
51	Fastener - 1/4-Turn Pin *	6
60	EXP Adjustment Spring * (see EXP tuning options)	6
65	Thin Drive Plate (1.2mm)	11
68	Thick Drive Plate (1.5mm) ++	1
69.1	TorqDrive™ Thin Friction Disk	11
70	Basket Lining Sleeve	12
85	Wedge Assembly *	6
86	Slave Cylinder Assembly	1

* Denotes parts assembled as part of EXP disk assembly.

++ This plate will only be used if necessary; see *Installation* section.

Visit Rekluse.com/support for a full parts fiche illustration and a listing of specific part numbers.

CLUTCH ASSEMBLY OVERVIEW

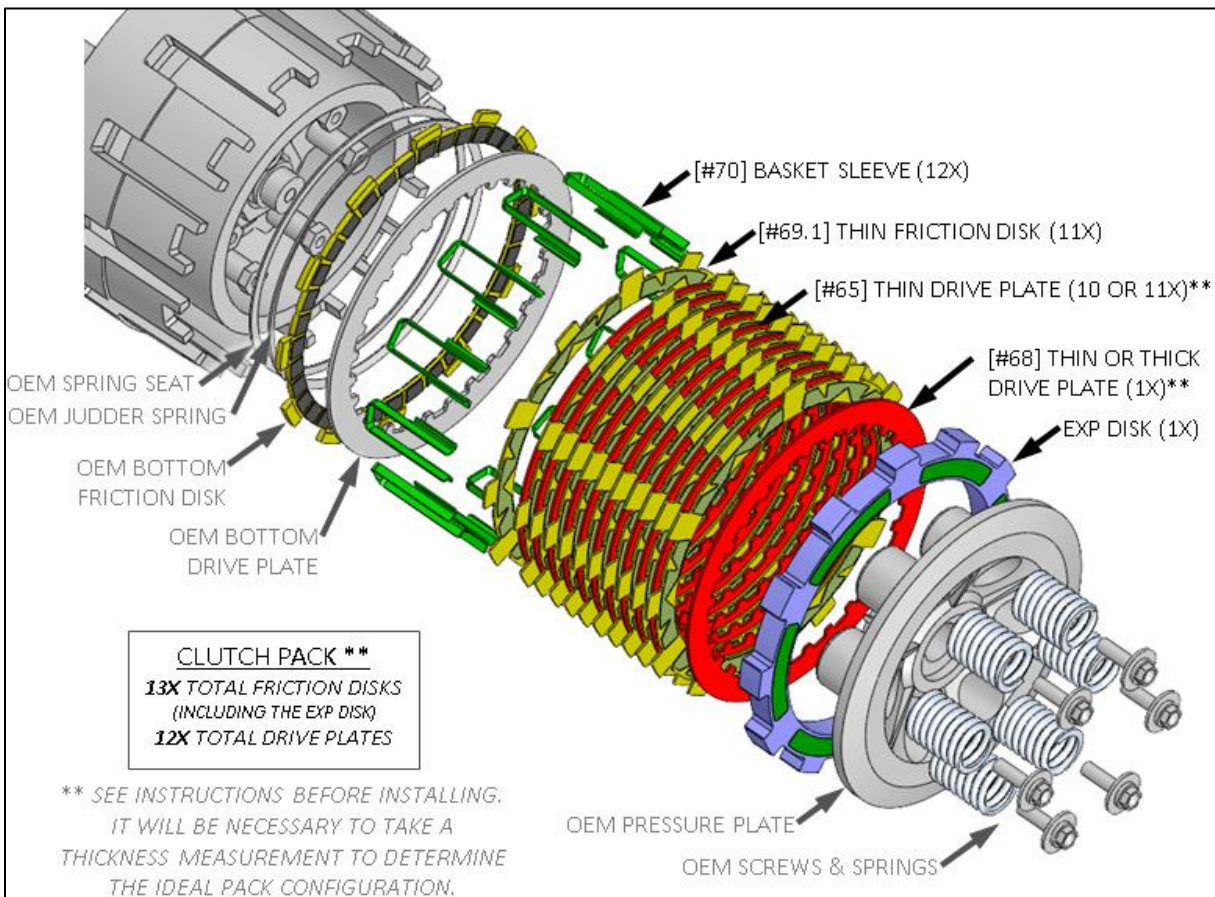

PREP & DISASSEMBLY

1. Soak the EXP disk **and** Rekluse friction disks in engine oil for at least 5 minutes.

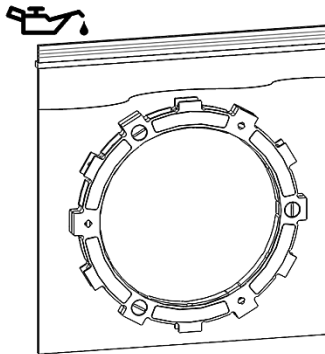

2. To avoid draining the oil, you can either:
 - a. Using the regular kickstand, block the rear tire up a few inches to increase the bike's lean angle.



- b. Lean the motorcycle against something sturdy on its left side.



Alternatively, you can stand the bike vertically on its center stand and drain the oil.

3. Remove the clutch cover bolts and clutch cover.

4. Remove the parts named in the following diagram, including the **entire** OEM clutch pack (all clutch plates and the judder spring & spring seat).

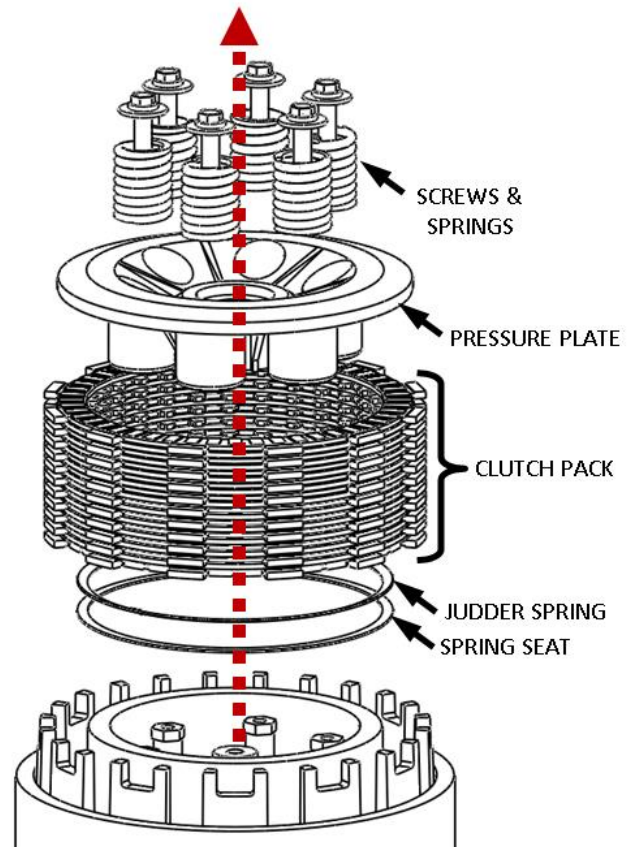

5. Inspect the basket for spring slop or notching in the tang faces. If heavily notched or worn, it is necessary to install a new basket. **Do not install the sleeves or use the product with a notched basket.**

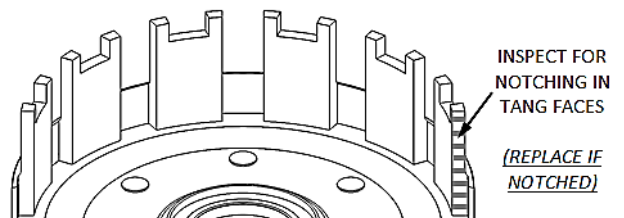

NOTE: Is it optional to leave the **judder spring** and **spring seat** inside the clutch, as you will be reinstalling them exactly as they were removed. We point them out so that you are aware of their presence and location, and so that they are not accidentally left out or misplaced. These parts function to reduce clutch noise during operation.

Inspect the **bottom friction disk** (the one that the judder spring and spring seat parts fit **inside**) for excessive wear or heat damage, as **it will be reused** with the EXP clutch pack. Replace this disk if necessary;

KTM part #:60032012000

Nominal disk thickness at the friction pads = .110" (2.79mm).

Alternatively, it is optional to use any of the wider OEM friction disks in place of it **and** the judder spring & spring seat. However, the clutch may produce more noise during operation without the judder spring and spring seat installed.

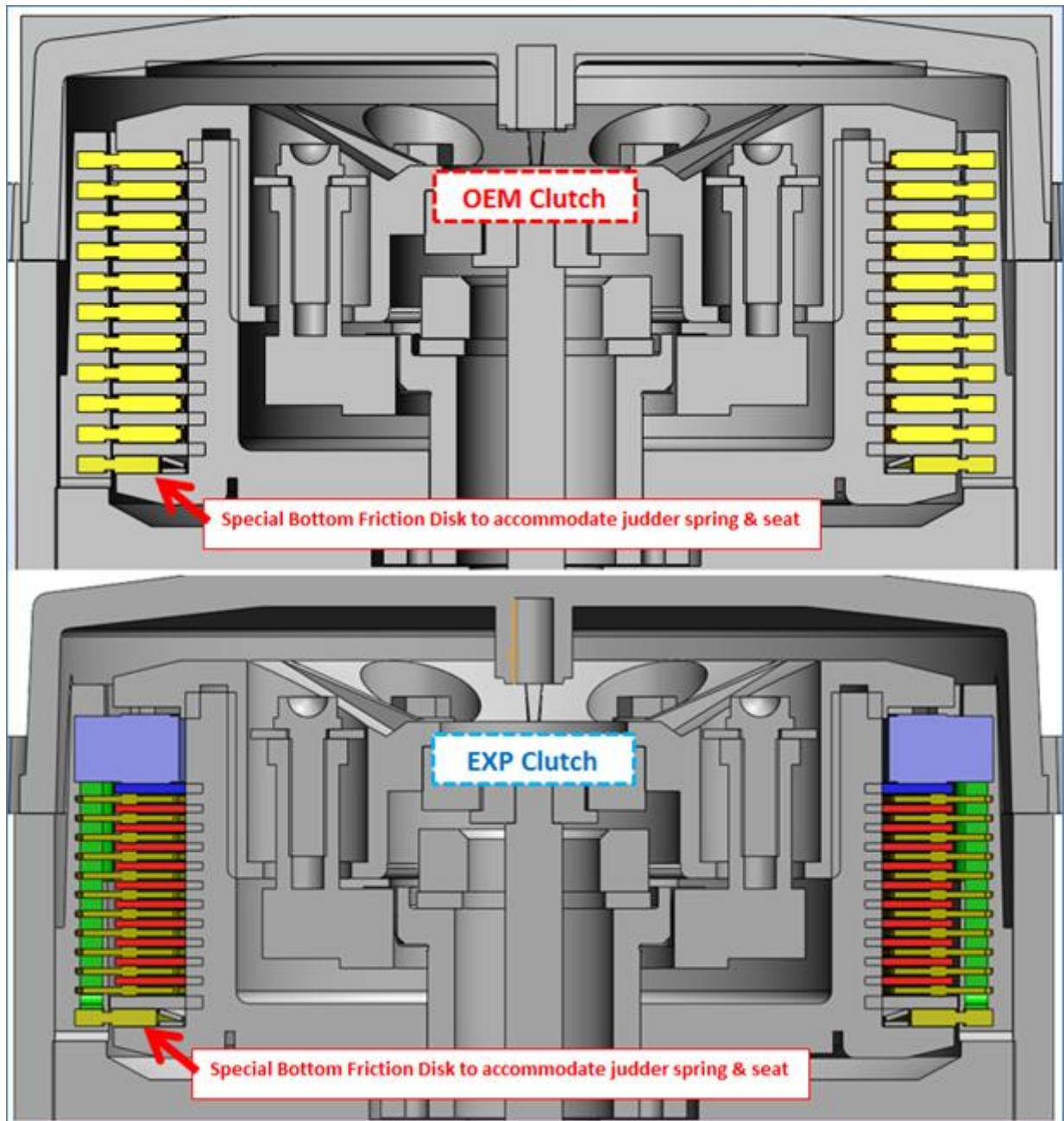

CLUTCH INSTALLATION

NOTE: Because this bike model's clutch pack involves so many plates, the slight variation in thickness of the plates can add up to be significant enough to alter clutch performance. For this reason it is necessary to measure the clutch pack thickness **before** installing it to determine the optimal configuration.

An extra *thick* .060" (1.5mm) drive plate, [#68], is included in a separate bag in your kit. Whether you will use this thick plate rather than a thin one, [#65], at the top of the clutch pack will be determined by measuring the overall clutch pack thickness in the following steps.

CLUTCH PACK OPTIONS: CUTAWAY OVERVIEW

Configuration A: *Thin* drive plate under EXP disk

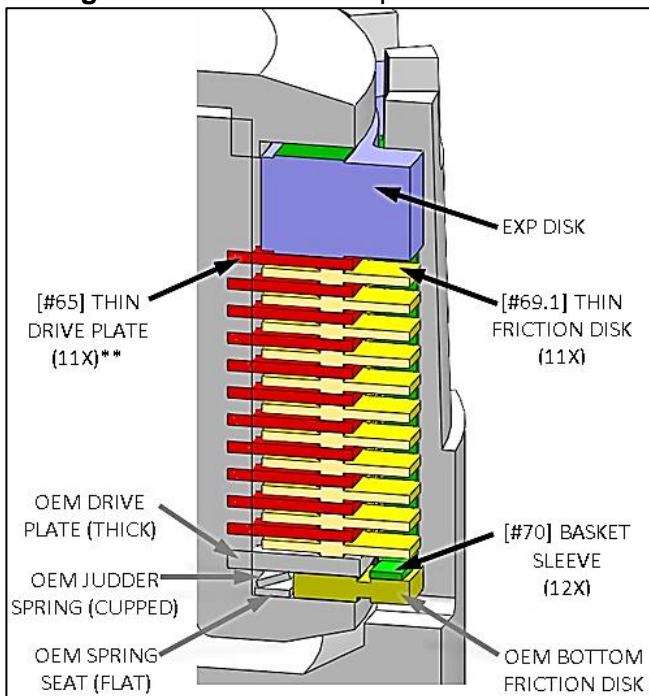

Configuration B: *Thick* drive plate under EXP disk

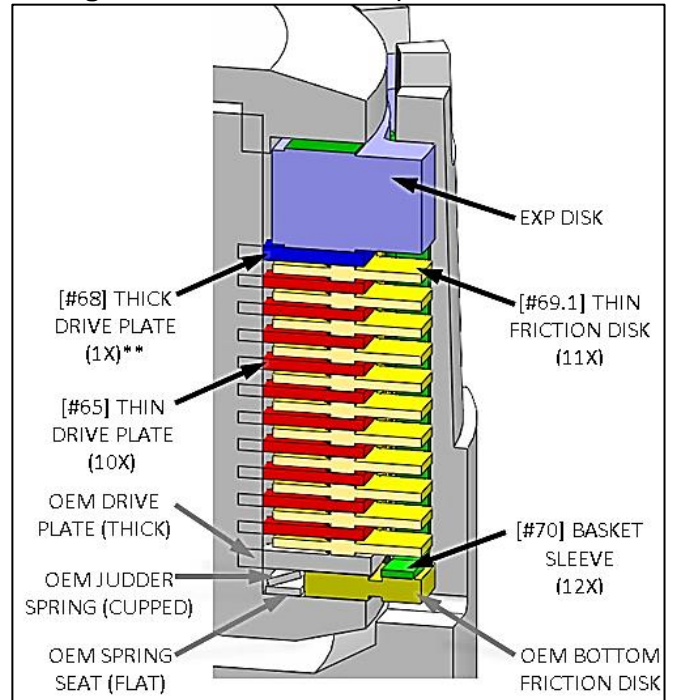

1. First, reinstall the OEM spring seat followed by the OEM judder spring, replacing them in the same manner in which they were stock (judder spring: cupped side facing out).

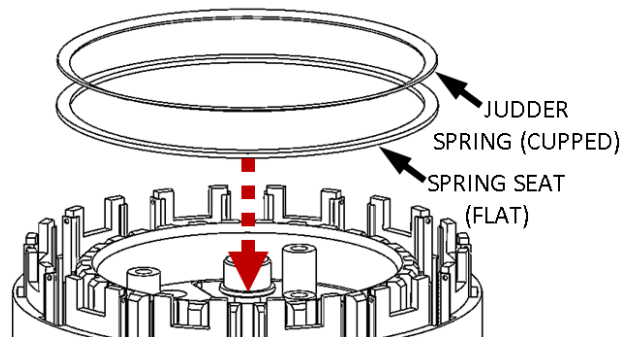

- Next, you will build clutch pack *Configuration A* on a workbench to measure the overall clutch pack thickness using calipers.

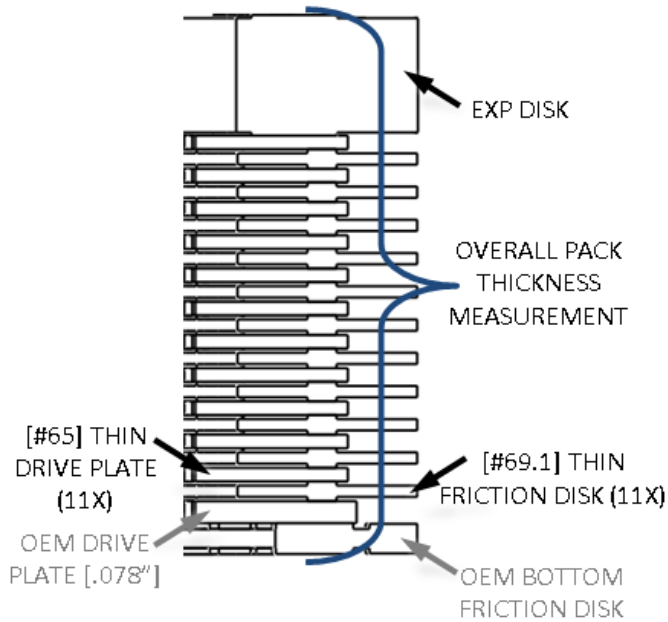

If the measurement is **1.930"** (49.0mm) or greater, install this *Configuration A* into the bike.

If the measurement is less than **1.930"** (49.0mm), **replace** the top drive plate—the one directly under the EXP disk—with the thicker Rekluse drive plate supplied in the separate bag ([#68] part number: 466-031). This will be clutch pack *Configuration B*.

NOTES:

I. Make sure you are measuring from pad-to-pad of the friction disks, not from any other points, including the tabs on the disks. We want to determine the axial space taken up by the clutch pack between the center hub and pressure plate.



II. Regardless of configuration installed, you will have one Rekluse drive plate left over that will **not** be installed in the bike.

Proceed with the installation following these steps:

- Reinstall the bottom OEM friction disk, followed by any one of the OEM drive plates.

NOTE: Refer to **Step 4** from the *PREP & DISSASSEMBLY* section to ensure that you are installing the correct friction disk at the bottom.

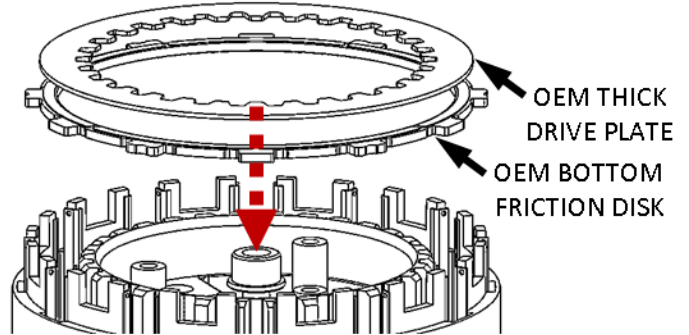

- Install the 12x Basket Sleeves [#70] into the deep tang slots of the basket, pushing them down in until they contact the tabs of the bottom OEM friction disk.

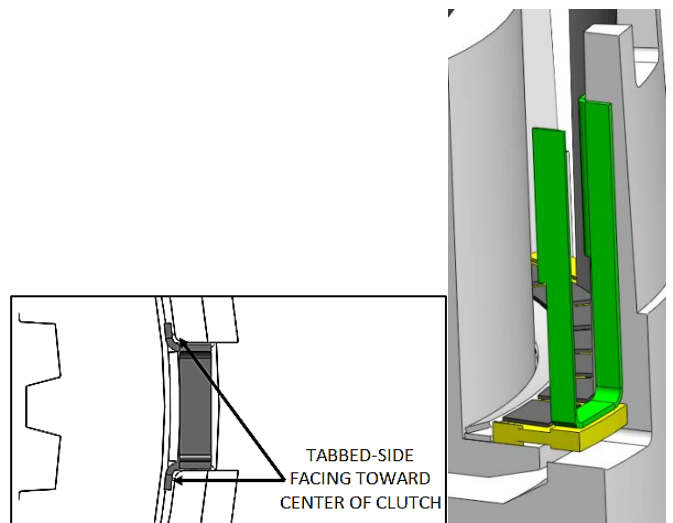
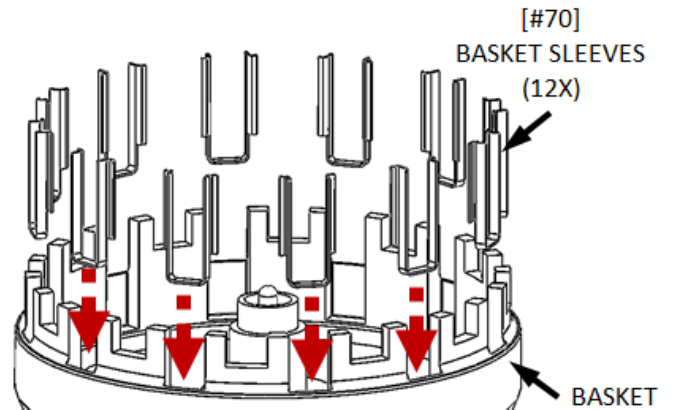

5. Starting with a friction disk, install the 11x Rekluse thin friction disks [#69.1] and the Rekluse thin drive plates [#65] in an alternating pattern. Whether you'll use a thin [#65] or thick [#68] drive plate at the top will depend on the measurement results of **Step 2**.

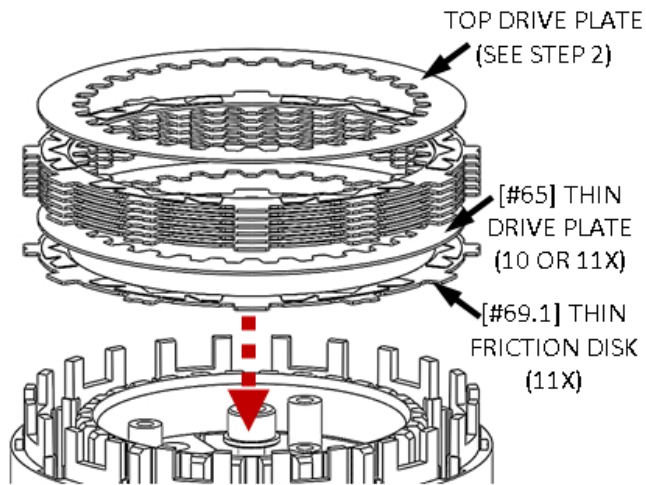

6. Next, install the EXP disk on top of the last installed drive plate. This disk is symmetrical and can be installed with either side facing out.

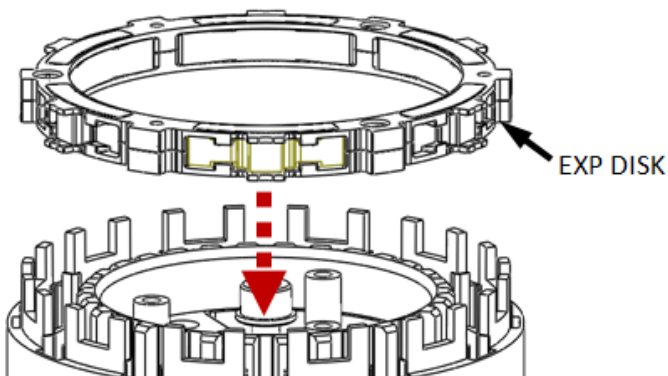

NOTE: Index all friction disk and EXP disk tabs only into the deep basket tang slots. Never install any disks into the half-slots in the basket.

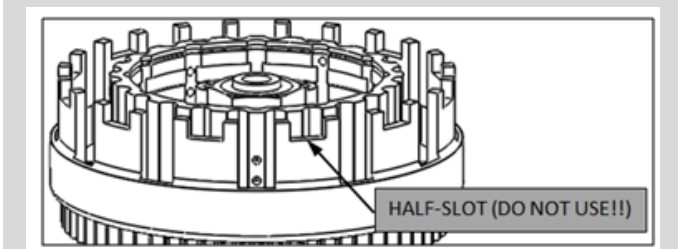

7. Reinstall the stock pressure plate, taking care to orient it correctly. There is only one orientation in which the pressure plate correctly fits inside the center hub, which is denoted by the arrows on both parts as shown.

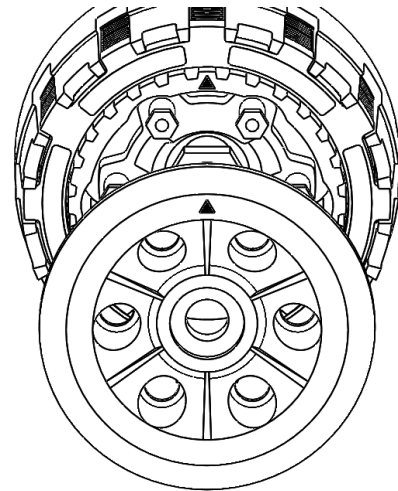

8. Reinstall the stock pressure plate springs & bolts; torque the bolts to OEM spec.
9. Reinstall the clutch cover and torque the cover bolts to OEM spec.

SLAVE CYLINDER INSTALLATION

Handle with care! During assembly there is a small ball bearing [#56] installed in the slave piston [#28.3] with a small amount of grease. When installing the Rekluse slave cylinder, make sure the ball is in place and that it does not fall out.

NOTE: When compressing the piston, fluid can shoot out from the slave cylinder port. Always be sure to wear eye protection.

1. Stand the bike up using its center-stand or place it on a suitable bike stand.

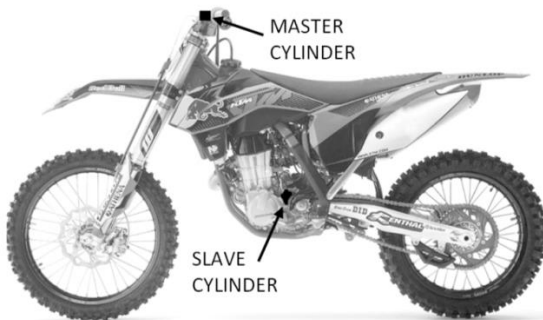

2. Using a 13mm wrench, remove the banjo bolt from the OEM slave cylinder. Be ready to catch the fluid that drains out of the line. Next, remove the OEM slave cylinder from the engine and set it aside.

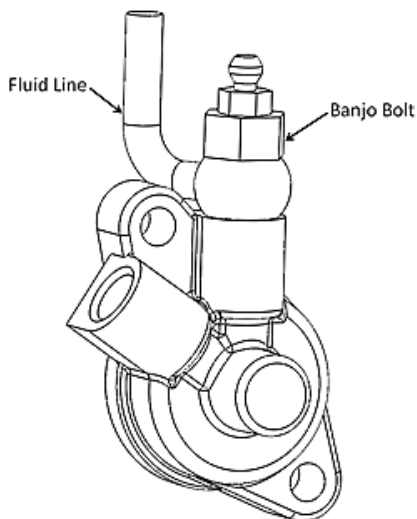

3. On a workbench (away from the engine), bleed the Rekluse slave cylinder by this procedure:
 - a. Using your thumbs, compress the slave cylinder piston until it bottoms out and hold it there.

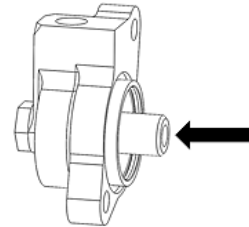

- b. While holding the slave cylinder piston, pour mineral oil into the slave cylinder port until it is full.

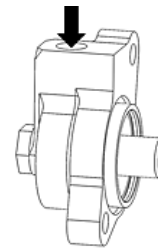

NOTE: Use only mineral oil in the clutch system. The use of brake fluid will result in seal damage to the OEM and Rekluse components.

- c. Release the piston and allow it to pull the fluid into the slave cylinder. Repeat this process until the slave cylinder remains full when the piston is released.

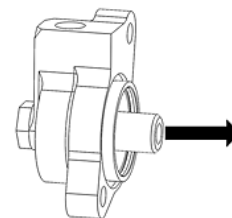

- a. There is a ball bearing installed in the slave piston with a small amount of grease. Confirm that this ball bearing [#56] is still inside the piston, and has not fallen out during shipping.

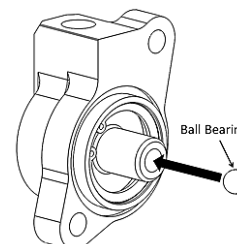

4. Install the Rekluse Slave Cylinder using the OEM bolts and the provided large O-ring [#53.4] between it and the OEM plastic spacer.

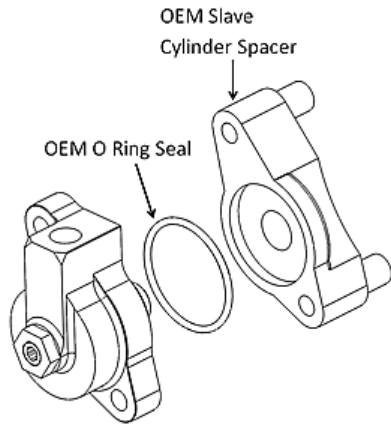

5. Re-install the OEM banjo bolt into the Rekluse Slave Cylinder using the provided crush washers [#50].
6. Remove the cap and bladder from the clutch master cylinder and top off the clutch fluid.

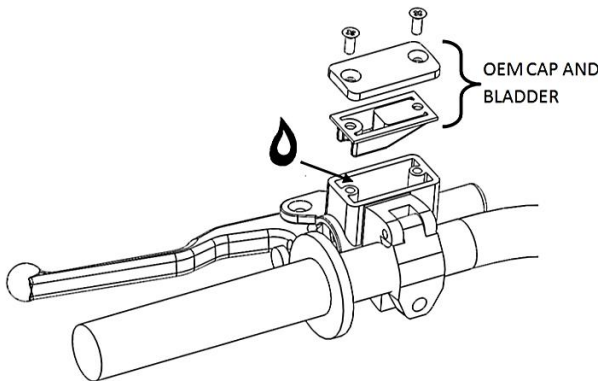

7. Fill the included bleeding syringe with fluid.
8. Attach the syringe line to the bleed port on top of the banjo bolt.
9. Using an 8mm wrench, open the bleed port and back-fill the system using the syringe until the master cylinder reservoir is full. Tighten the bleed port.

NOTE: Make sure there are no air bubbles in the clear hose of the bleeder syringe before back-filling the system.

10. Check that the clutch lever functions properly. If not, repeat the back-bleeding steps after removing any excess fluid from the master cylinder.

11. Finally, remove the bleed tube and clean the area of spilled fluid. Replace the dust boot over the bleed port.

INSTALLED GAP SETTING

DEFINITION: the “Installed Gap” is the separation in the clutch pack created by the adjustment of the Adjuster Screw in the Slave Cylinder. This gap is what allows the clutch to spin freely until the desired RPM is reached for engagement; it must be set correctly for optimal performance.

NOTICE

Failure to check and verify Free Play Gain can cause failure or damage to this product. Setting the correct gap is critical for clutch performance.

1. Using the long end of a 4mm Allen key, turn the adjuster screw clockwise until it stops under moderate pressure. You are trying to feel for the point at which the screw bottoms on the slave piston and the throwout will start to lift the pressure plate. This is the “starting point”.

NOTE: It may take a few tries to find the point at which the system is bottomed out. You should feel a distinguishable change in turning effort at this point.

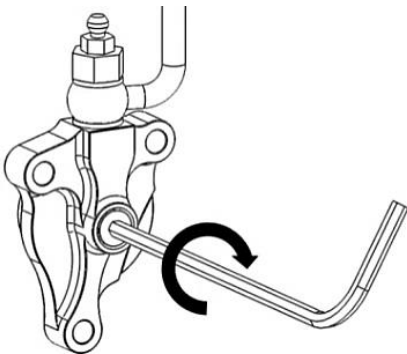

2. Once you have found the starting point, turn the adjuster clockwise 1 full turn. **This is NOT your final setting**, but it is a good reference point for using free play gain to find the final, correct Installed Gap setting.

3. Pursue the steps in the following section: “Checking Free Play Gain” to achieve the desired adjuster-screw setting.
4. When finished, top off the master cylinder with clutch fluid and reinstall the OEM cap.

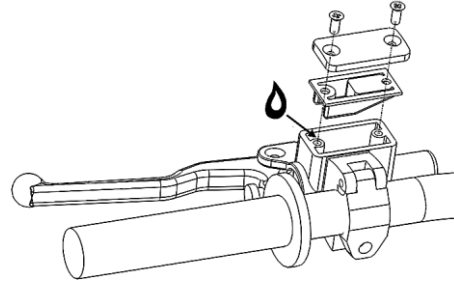

CLUTCH LEVER STICKER

1. Install the provided warning label on the clutch lever so that the writing is visible to the rider as shown.



CHECKING FREE PLAY GAIN

WARNING

Always make sure that the bike is in NEUTRAL before checking Free Play Gain. Failure to do so may result in the bike lurching forward, and loss of control and/or injury may result.

NOTE: Before performing this step, please visit our website at rekluse.com/support to view the TECH VIDEO entitled “How to Check Free Play Gain”.



“Lever Free Play” is essentially the “slack” in the clutch lever before it starts actuating the clutch. Applying a light finger pressure will take up this slack.

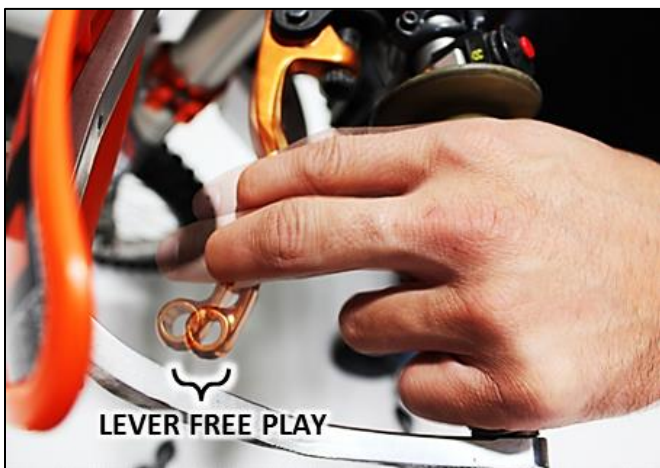

“Free Play Gain” is the increase of lever free play as the auto-clutch engages. This happens when the RPM increase from idle through around 5000 RPM. Free Play Gain is caused by the expansion of the EXP disk which lifts the pressure plate away from the throwout assembly.

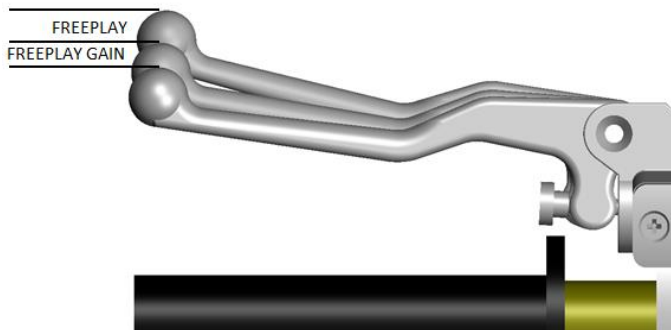

Optimal Free Play Gain yields **1/8” (3mm)** of clutch lever movement, measured at the end of the lever. This measurement at the lever correlates to achieving the ideal installed gap.

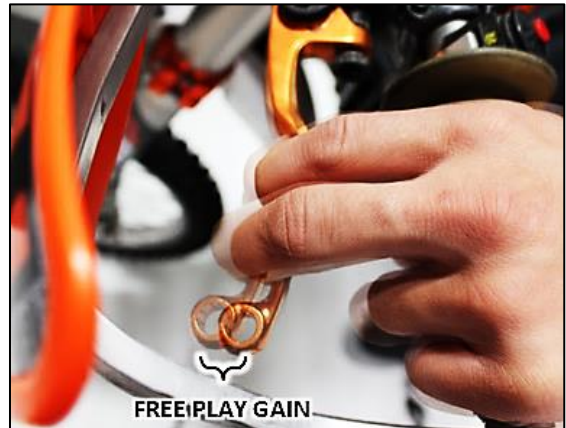

The following steps explain two ways to check Free Play Gain. One will use the rubber band that has been included in the clutch kit and one explains using your hand, which you will perform before every ride.

Place the bike in neutral, start the engine and let it warm up for 2-3 minutes.

NOTICE

Failure to check and verify Free Play Gain can cause failure or damage to this product. Setting the correct gap is critical for clutch performance.

WARNING

Verify that the bike is in NEUTRAL before checking Free Play Gain. Failure to do so may result in the bike lurching forward, and loss of control and/or injury may result.

A Rekluse auto-clutch can make your motorcycle appear to be in neutral when in gear, even when the engine is running and clutch lever released.

Motorcycles equipped with a Rekluse auto-clutch can move suddenly and unexpectedly and cause riders to lose control.

To avoid death, serious injury, and/or property damage, always sit on the motorcycle to start it.

Rubber Band Method:

It is recommended that you use this method first to find your Free Play Gain so you can see what it is. Then, check it by hand as well so that you can effectively and comfortably check free play gain every time you ride.

Wrap the included rubber band around the outer end of the handlebar grip and attach it to the ball end of the clutch lever.



With the bike at idle in neutral, quickly blip (rev) the engine to at least 5,000 RPM and let it return to idle. **The clutch lever should move in about 1/8" (3mm) toward the handlebar as you rev the engine.**

NOTE: If you are not getting the correct lever movement, see the "Free Play Gain Troubleshooting Guide" on the next page.

Hand Method:

Free play gain should also be checked using your hand, as you will check it by hand before every ride. With the bike at idle, apply enough pressure to the lever to take up the initial freeplay (slack) shown in the photos on the previous page. While continuing to apply light pressure, rev the engine to at least 5,000 RPM. **The clutch lever should move in 1/8" (3mm) under your finger pressure as you rev the engine and the auto-clutch engages.**

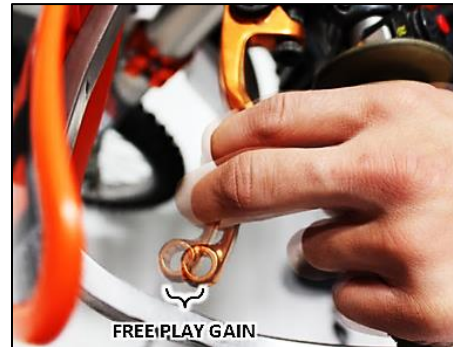

FREE PLAY GAIN TROUBLESHOOTING

Each adjustment should be done in small increments - one tick mark at a time. After each adjustment, repeat the rev-cycle until optimal free play gain is achieved.

Symptom:

- Clutch lever moves in too far (too much free play gain)
- Clutch has excessive drag
- It is difficult to fully override the clutch with the lever

Answer: Installed Gap is too small

Solution: Turn the Adjuster Screw inwardly (clockwise) to increase the Installed Gap.

Symptom:

- Clutch lever does not move enough or does not move at all (too little free play gain)
- Clutch is slipping

Answer: Installed Gap is too large

Solution: Turn the Adjuster Screw outwardly (counter-clockwise) to reduce the Installed Gap. It may be helpful to re-find the starting point.

BREAK – IN

Follow these procedures for a new installation and any time new friction disks or EXP bases or wedges are installed.

1. Rev cycles: Warm up the bike for 2-3 minutes. With the bike in neutral and your hand **off** of the clutch lever, rev the engine 10 times, being sure to let it **return to idle** between each rev cycle.
2. With the engine running, pull in the clutch lever and click the bike into gear. Slowly release the clutch lever. The bike should stay in place, perhaps with a slight amount of forward creep.
3. Now that the bike is idling in first gear, slowly apply throttle to begin moving. To break in the clutch components, perform the following roll-on starts in 1st and 2nd gear without using the clutch lever: In 1st gear, accelerate moderately to approximately 5,000 RPMs and come to a stop—repeat this 5 times. Next, starting in 2nd gear, accelerate moderately to approximately 5,000 RPMs then come to a stop—repeat this 5 times.
4. Now that the EXP is broken-in and the clutch is warm, re-check free play gain at your clutch lever and adjust if necessary. Your clutch pack will expand with heat, so final adjustments should be made when the bike is warm. Now you are ready to ride!

WARNING: DO NOT RIDE WITHOUT SUFFICIENT FREE PLAY GAIN!

Checking free play gain is easy and takes less than a minute to perform. For optimum performance and longevity, check free play gain when the bike is warm at the start of every ride.

CLUTCH NOISE & DRAG

Although it is harmless, some bike models may have “squeal” or “chatter” coming from the clutch at low RPM as it engages. Clutch squeal is caused by the clutch components vibrating as the clutch engages and can become more audible as the clutch gets hot. For bike models that tend to have clutch squeal or chatter here are some recommendations to reduce or eliminate it:

- **Oil:**
Rekluse recommends that you have fresh, clean JASO-MA rated oil for best clutch performance. Dirty or old oil can make the clutch more likely to squeal or chatter. Some heavy-duty oil stabilizers or other additives have been known to reduce noise and make shifting smoother. Be sure that any additives you might use are approved for use in wet-clutch motorcycles.
- **Installed Gap:**
Adjusting the Installed Gap will NOT affect clutch squeal or chatter.
- **Drag:**
Now that your clutch has more friction surfaces, the clutch may drag more than stock and possibly may drag more noticeably when cold. If this occurs, warm the bike up by allowing it to idle for a few minutes before riding. If drag persists and your installed gap is correct, inspect your clutch plates.
- **EXP Spring Setting:**
If your oil is warm and the clutch plates configuration is in spec, yet your bike wants to drag, pulse, or chatter during idle or takeoff, it may be necessary to tune the EXP springs for a higher-RPM clutch engagement. See the “EXP Tuning Options” section on the following pages for instructions.

LEVER SAFETY STRAPS

This kit includes 2 Velcro-type straps to be used to secure both the clutch and front brake levers when the bike is parked. These are intended to reduce the risk of injury or damage that may occur from the bike rolling or launching unexpectedly with or without a rider on it. Use the straps to pull both levers as tight to the bar as possible as shown in the photos every time you park or leave the motorcycle. Refer to the Safety Information document for more information.

Brake Lever Strap: for use as a parking brake.



Clutch Lever Strap: to prevent launching.



Rekluse auto-clutch-equipped motorcycles may roll back or move suddenly and unexpectedly and cause riders to lose control.

An auto-clutch-equipped motorcycle will move in gear with the engine off because the clutch is only engaged when engine RPM is greater than the engagement threshold of the auto-clutch. Engine compression will not prevent motorcycles from moving while in gear.

A Rekluse auto-clutch can make your motorcycle appear to be in neutral when in gear, even when the engine is running and clutch lever released.

To avoid death, serious injury, and/or property damage:

- Use the included brake lever strap to secure the front brake lever to the handlebar as a parking brake.
- Use the included clutch lever strap when the motorcycle is parked to secure the clutch lever to the handle bar, thereby completely disengaging the clutch.

EXP TUNING OPTIONS

Included are spring options to tune the engagement RPM of the EXP friction disk. **The EXP friction disk comes from Rekluse set with the recommended “Medium” setting for the 950 models.** See the following charts for alternative settings.

Adjusting the engine idle speed to match your engagement setting is important and greatly affects the overall feel of how the EXP disk engages**. To prevent freewheeling and maximize engine braking, set the idle so there is a slight amount of drag while the bike is idling in gear and warmed up. The idle should not be so high as to move the bike forward in gear with the throttle closed. However, with a small opening of the throttle the bike should move forward.

NOTE: The idle settings differ between the 950 & 990 models.

- **950cc bikes are carbureted**, and KTM’s recommended idle setting is 1,400 RPM when the engine is warm. Based on test results, Rekluse recommends setting the idle to 1,450 for best clutch engagement performance and to avoid excessive freewheeling effects. During operation, the idle will usually jump +/-50 RPM, so setting the idle to 1,450 will help ensure the idle does not sporadically dip down into the 1,300s.

- ****990cc bikes employ EFI**, and the idle setting is *not* adjustable without a special electronic controller. *For 990 engines, it is recommended to install the 3 Red & 3 Blue springs in the EXP to better match this bikes’ stock idle RPM.*

950cc V-Twin LC-8

ENGAGEMENT SETTING	SPRING CONFIGURATION
Low	3 Silver & 3 Red Springs
Medium <i>(the EXP is pre-assembled with this setting)</i>	6 Red Springs
High	3 Red & 3 Blue Springs

990cc EFI V-Twin LC-8

ENGAGEMENT SETTING	SPRING CONFIGURATION
Low <i>(the EXP is pre-assembled with this setting)</i>	6 Red Springs
Medium <i>(recommended setting)</i>	3 Red & 3 Blue Springs
High	6 Blue Springs

It is **NOT necessary** to disassemble the EXP halves to change springs! To change springs, remove 3 of the ¼-turn pins from one side of the EXP, replace springs, and re-install ¼-turn pins. Next, flip the EXP disk over and repeat on the other side if necessary. To maintain even pressure when using two different color spring sets, install one color set of 3 on one side of the EXP and the remaining color set of 3 on the other side.

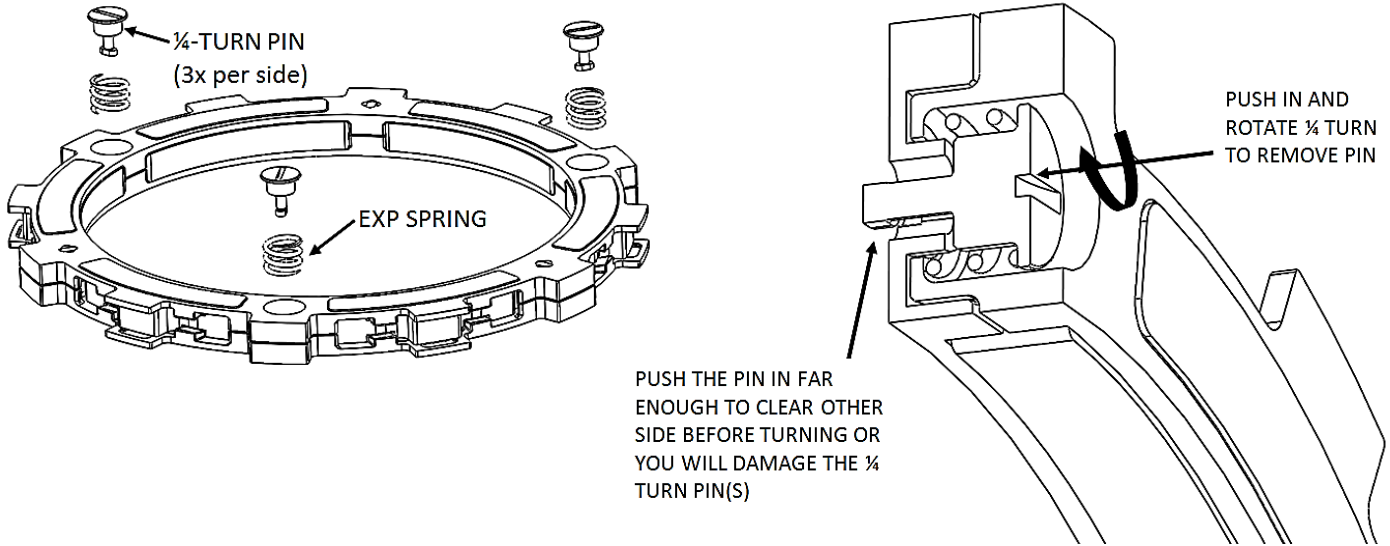

CAUTION: If you disassemble the EXP, bearing pads may fall out or be stuck to the ramp surfaces of the EXP bases. Take care to ensure all pads are correctly placed into wedge pockets using gentle pressure to avoid damage to the pad surfaces before reassembling the EXP. Properly seated pads will be secured in place once the EXP is reassembled. Operating the clutch without the pads in place will cause part damage or failure.

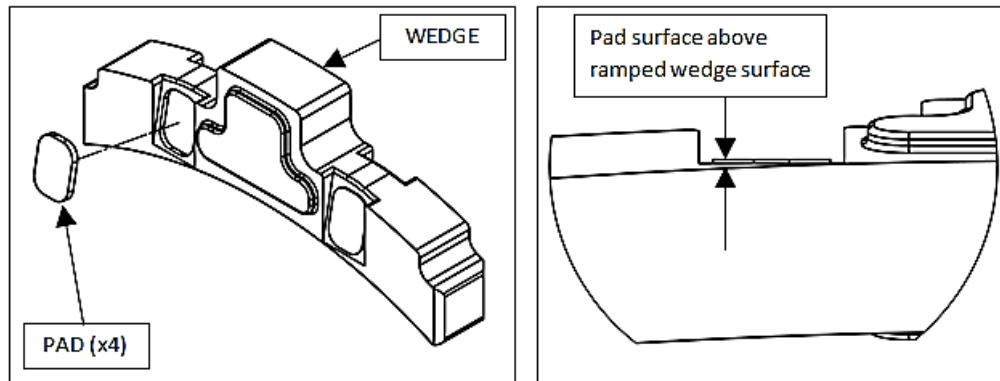

MAINTENANCE

- Maintain adequate free play gain, checking before every ride and adjusting if necessary.
- Keep up with regular oil changes as per the bike manufacturer's recommendations. Clutch function and longevity depends on oil quality.
- Inspect all of your clutch parts at regular engine service intervals for signs of wear or excessive heat, and replace components as necessary.

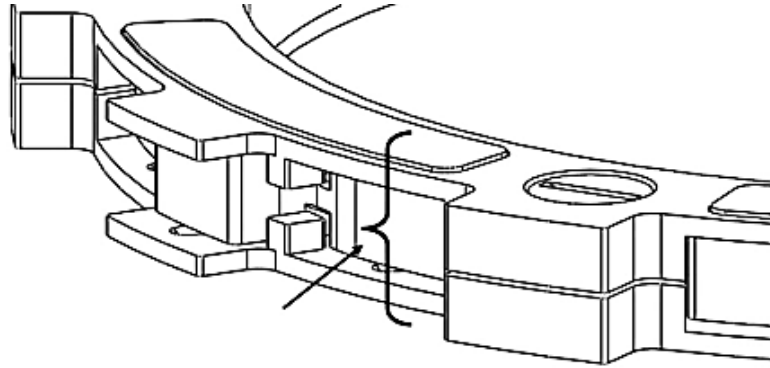

- If you find yourself making frequent slave cylinder adjustments to fix free play gain, drag, or performance, it is likely time to replace worn clutch disks. Measure your friction disks and replace as necessary.
 - o Rekluse thin friction disk minimum allowable thickness = **0.068" (1.73mm)**
 - o EXP disk minimum allowable thickness = **0.416" (10.57mm)**
- Excessive heat or clutch slip can cause premature clutch failure. Once extreme temperatures are reached, irreversible damage will occur. Inspect your clutch plates using the guide on the next page; if the friction disks look burnt or glazed, or the drive plates are warped, it is best to replace the entire clutch pack.
- Repeat the break-in procedure anytime the friction disks or EXP bases or wedges are replaced. Always soak friction disks or EXP bases in oil for at least 5 minutes before installing.

DISK INSPECTION

These are best viewed in color by downloading the PDF from rekluse.com/support

When inspecting the clutch pack, the following pictures can be used as reference:

Drive Plates – If the clutch pack is getting high amounts of heat, purple, blue, or black color can be seen on the drive plate teeth. See Pictures below.



Normal Heat
(Brownish)

High Heat
(Blue, Purple)

Excessive Heat
(Black)

Friction Disks – Due to the dark color of the friction material, the friction disks will appear almost black as soon as they are put in oil. During inspection, look for glazing of the friction material. Glazing will appear shiny and feel like glass, even after oil is cleaned from the friction disk.



Normal Friction Pad



Glazed Friction Pad

BUMP-START INSTRUCTIONS

If your bike needs to be bump-started due to a dead battery or any other reason, follow the steps below to quickly bump-start your bike.

1. Use a 4mm Allen key to turn the adjustment screw counter-clockwise, just until it turns freely and no longer is preloading the pressure plate inside the clutch.
2. Bump start the bike. The clutch will function like a manual clutch at this point.
3. Once the bike is started, readjust the free play gain as per the instructions to reset the installed gap.

Visit Rekluse.com for more detailed instructions, videos, parts-fiche documents, and warranty information.

