

# RMS-285F - TORQ-DRIVE CLUTCH (HD)

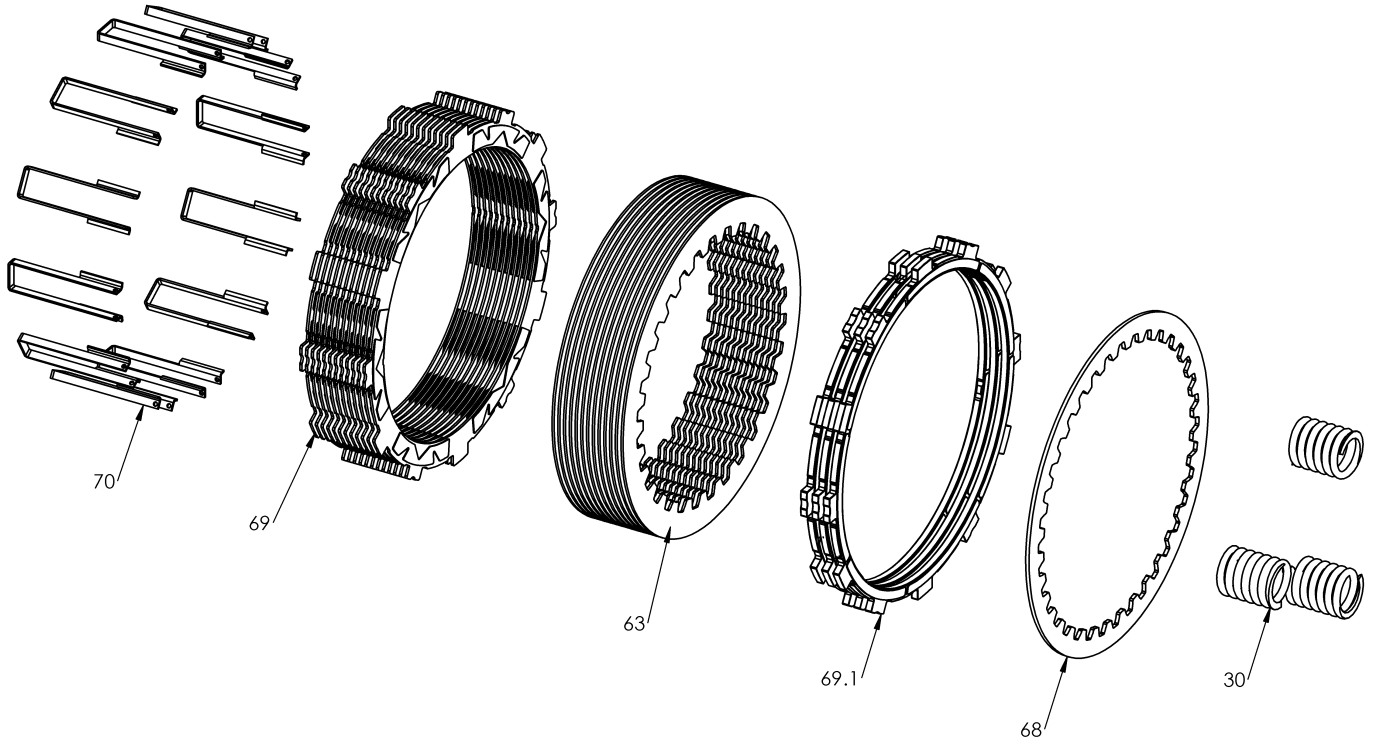

Item	Part Number	Item Description	Qty
63	460-601C	DRIVE PLATE - 0.040in BT CVO, 1190	13
68	466-602B	DRIVE PLATE - 0.065in BT Top CVO, 1190 (indexes to pressur	1
69.1	469-309B	FRICITION DISK - BT - Thick .150in 3.81mm	3
69	469-530A	FRICITION DISK - HD Thin Friction Disk - 2-Segment Pads	12
70	471-301	BASKET SLEEVE - H2.08 - 4S	12
Not Shown	744-124A	CLUTCH SPRING KIT - Harley-Davidson - Light Springs	1
30	744-125A	CLUTCH SPRING KIT - Harley-Davidson - Extra Light Springs	1
Not Shown	744-126A	CLUTCH SPRING KIT - Harley-Davidson - Standard Springs	1
Not Shown	821-013A	Prop. 65 Warning Label	1